



ICE MACHINES

USA PRICE LIST 2022

 **NATURAL**
REFRIGERANT





USA PRICE LIST US\$ 2022

About ITV Ice Makers

ITV Ice Makers, Inc. is a dynamic and innovative U.S Company, with its factory in Spain.

After more than 40 years in the business, with over half a million customers in nearly 100 countries, we strive to surpass our world-renowned reputation of keeping these customers happy. Additionally, our commitment is to introduce new energy-efficient ice makers that meet the ever-changing market and demand of new customers. We seek to accomplish this through state-of-the-art production capabilities, efficient management systems, and the use of clean and environmentally friendly technologies.

As a family-owned business, our values are founded on integrity and professional ethics. We are committed to establishing internal policies to reflect positively on people's health and safety, with the flexibility to listen, learn and be proactive and responsive to the needs of our customers. With this as our mission, we are able to maintain the passion to achieve excellence and success into the future.

ITV's vision is based on continuous and ongoing improvement of our processes, establishing goals and objectives in order to improve our production systems while maintaining maximum efficiencies.

ITV's main manufacturing facility is vertically integrated, automated with robotic machinery, reducing labor intensity, and produces a finished product that can be described with four basic words:

QUALITY - SIMPLICITY - RELIABILITY - SERVICEABILITY

Sincerely,

Cristina and Javier

Handwritten signatures of Cristina and Javier in black ink.

About ITV Ice Makers, Inc.

ITV has made a large commitment to the US market with the opening of our new headquarters in Orlando, FL. This facility will handle all operations from accounting, service, and support. All parts and accessories will be stocked in this facility. Additionally, we have partnered with other parts houses and centers throughout the country. We have also strategically set up distribution centers around the US, which will stock all of our equipment and filtration systems. These facilities are located in Texas, New Jersey, Florida and California.

Customers can speak directly to our service team who will coordinate parts and dispatch service agents when needed. Our team will get your problem solved in a timely manner to get the customer back up and running.

Our commitment to the US marketplace has also brought new models. We have our new 22" series machines along with the bins and dispensers. We also have a new cart transport system that is offered in a single and a double cart unit. ITV will continue to expand our line to get the units our customers demand.



Table of contents

TERMS & CONDITIONS	5
WARRANTY	5
SERVICE & SUPPORT	5
SPIKACUBERS	8
Undercounter.....	10
Modular.....	11
Remote.....	12
Remote condensers.....	13
HOTEL DISPENSERS	14
DELTACUBERS	15
Delta Gourmet Cubers.....	15
IQN	18
IQ NUGGETS.....	18
IQFLAKERS	20
Flaker with built-in bin.....	22
Modular.....	23
IQF.....	24
Split.....	25
STORAGE BINS	26
Slope Front Bins.....	27
Ice Bagger.....	25
Ice Transport Systems - Single Cart.....	28
Ice Transport Systems - Double Cart.....	29
WATER FILTRATION & CLEANING	30
Water filters and replacement cartridges.....	30
Scale cleaner.....	30
INSTALLATION GUIDELINES	31
ICE USAGE GUIDE	31
ITV AND THE ENVIROMENT	32

Terms & Conditions



- Price list is effective January 1, 2022 and supersedes all previous price schedules.
- Prices are subject to change with no previous notice.
- Dimensions do not include adjustable legs from 4" (10.2 cm.) to 6" (15.2 cm.) DELTA, IQ & SLOPE FRONT BIN series only, and from 6" (15.2 cm.) to 6.5" (16.5 cm.) ICE & WATER DISPENSERS and SPIKA series only.
- Freight is F.O.B. nearest ITV warehouse with available product.
- Shipping fee may apply for drop ship orders. Orders requiring special needs, i.e. Lift gate, etc., will be extra.
- All deliveries that have been signed for will be the responsibility of the customer to file claims. Please inspect all deliveries for damage before signing. If unit is damaged refuse delivery and notify ITV. Concealed damage must be reported to itv within 72 hours.
- Terms of sale are subject to ITV Ice Makers, Inc. credit approval.
- We require the installation of a water filtration kit or "whole house" water filtration system to ensure warranty coverage. Maintenance issues resulting in hindering the proper function of the equipment will be the responsibility of the end-user.
- RMA must be issued for returned machines. Returns are subject to 20% restock fee plus return freight.

SPIKA & DELTA CUBE SERIES

36 months parts & labor + 24 additional months parts on compressor and evaporator.

IQ FLAKE/NUGGET SERIES

36 months parts & labor + 24 additional months parts on compressor + 24 additional months on Auger.

ICE STORAGE BINS

36 months parts & labor.

HOTEL ICE & WATER DISPENSERS

36 months parts & labor.

RESIDENTIAL WARRANTY

All series 90 days parts & labor.

ITV Service and Support

ITV commits to making the highest quality ice machine in the industry. If you do have a service issue, we pride ourselves on after-sales support. Our service department is trained to deal with any aspect of repair based on the end user's situation. ITV's extensive service network of authorized service agents reaches coast to coast to meet the needs of the clients.

Customers can talk with our knowledgeable staff to get the problem resolved quickly. Parts are readily available for delivery anywhere throughout the US. This allows us to get your unit back up and running fast and done the first time.

Feel free to contact us at:



888 - 488 - 1423



service@itvice.com

SPIKA Cubers



SPIKA Series offers the "Classic American" style of ice available in full and half dice shaped cubes, that will meet the most stringent demands of the food service industry.

A new revolutionary system for water distribution, patented by ITV, allows water to "cascade" over the entire evaporator, allowing SPIKA cubes to take form perfectly.

The Vertical Plate Evaporator, specially designed by ITV's engineers, is much more energy efficient than others, resulting in lower operating cost and greater savings, while maintaining the utmost environmental friendliness.

Beverages are chilled in a very short time while not affecting the taste. The SPIKA Series meets the most demanding requirements with fast ice production.

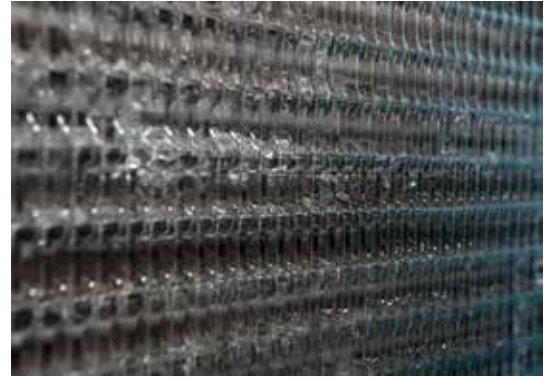

Vertical Plate Evaporator

3 YEARS
WARRANTY
PARTS & LABOR









Half dice
1/2" x 1"
1.25 x 2.5 cm









Full dice
1" x 1"
2.5 x 2.5 cm







SPIKA Cubers

-  **NATURAL REFRIGERANT:** Natural gas r290 with very low global warming potential which also reduces the energy consumption.
-  **WATER DISTRIBUTOR:** Increases resistance against scale build up. Easily removable and cleanable.
-  **INLET WATER CONNECTION THROUGH EVAPORATOR:** Helps to harvest; precools water; assists energy recovery.
-  **EASY ACCESS FOR SERVICE AND INSTALLATION:** Designed to have better access to all components making installation and servicing operations easier.
-  **OPERATING LIMITS:** Tropicalized machines (Class T); Suitable for low temperature environments of 41° (5°C) Air and Water and high temperature environments of 109°F (43°C) (Air), 95°F (35°C) (Water).
Water pressure: Min. 10 psi. (0.7 bar.)/ Max. 85 psi. (6 bar.).
NOTE: Install a pressure reducer if water inlet pressure is more than 85 psi. (6 bar.).
-  **MORE ENERGY EFFICIENT:** Reducing water and electricity consumption.
-  **WARRANTY:** 36 months parts and labor + 24 additional months parts on both compressor and evaporator.

UNDER-COUNTER SERIES

-  **DUAL SWITCH:** External switch allows to turn the machine on/off easily. Removing the top cover, we have the Ice/clean cycle switch on one side of the electrical box.
-  **SEAL-LESS PUMP OUTSIDE ICE ZONE**
-  **STRONG INOX FRAME. 304 STAINLESS STEEL CONSTRUCTION:** Box-type frame with stainless steel supports, makes the machine stronger and allows servicing operation without disassembling the entire machine.
-  **FRONT VENTILATION:** Condensing unit permits 100% front ventilation, air inflow and outflow through the front grill on under counters, thus permitting embedded installation. Airflow is rear intake and exhale on sides.
-  **INSULATED STORAGE BIN:** Storage bin with polyurethane foam insulation gives higher rigidity with lower heat transmission. Isolated but not refrigerated bins.
-  **ELECTRICAL SPECIFICATIONS:** 115V/60Hz./1 - Fuse Size 15 - Nema Plug Type 5-15P.
*Also available 208-230V/60Hz. - 220V/50Hz. (Special Order).

MODULAR SERIES

-  **22" WIDE:** Standard width for modular ice makers. Fits standard 22" Beverage Dispenser and all 22" wide Storage Bins.
-  **30" WIDE:** Standard width for modular ice makers. Fits standard 30" Beverage Dispenser and all 30" wide Storage Bins.
-  **ELECTRICAL SPECIFICATIONS:** MS 500—115V/60Hz/1—Plug 5-15P. *Also available 208-230V/60Hz—220V/50Hz. (Special Order) MS 1000—208-230V/60Hz/1—Plug 6-15P. Also available three phase.
-  **HEAVY DUTY CONSTRUCTION:** 304 Stainless Steel construction with plastic top cover and grill.
-  **DUAL SWITCH:** A rear switch allows to turn the machine on/off easily. Remove the front cover for access to the ice/cleaning cycle switch.

SPIKA Under-counter



Half dice
1/2" x 1"
1.25 x 2.5 cm



Full dice
1" x 1"
2.5 x 2.5 cm

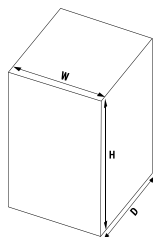

SPIKA NG 130			SPIKA NG 160			SPIKA NG 230			SPIKA NG 360		
W	D	H	W	D	H	W	D	H	W	D	H
21.07"	23.43"	31.07"	21.07"	23.43"	31.07"	26"	27.56"	32.76"	30"	30"	32.76"
53.5 cm	59.5 cm	78.9 cm	53.5 cm	59.5 cm	78.9 cm	66 cm	70 cm	83.2 cm	76.2 cm	76.2 cm	83.2 cm

*Dimensions do not include adjustable legs from 6" (15.2 cm.) to 6.5" (16.5 cm.)

ITEM #	COND. UNIT	CUBE STYLE	DAILY PRODUCTION LBS./ KG 70°F - 50°F 90°F - 70°F 21°C - 10°C 32°C - 21°C	CUBES CYCLE	STORAGE LBS./ KG.	WATER USAGE GAL./100LBS. / L./HR. 90°F - 70°F	VOLTAGE	KWH/100 LBS. - AMPS.	NET WEIGHT. LBS./ KG.	LIST PRICE
--------	------------	------------	--	----------------	----------------------	---	---------	-------------------------	-----------------------------	---------------

NG 130

NG 130 A1H	17042U	A	HALF	139/63	112/51	150	44.1/20	22.4/4	115V/60Hz/1	7.55-5.45	106/48	\$4.296
NG 130 A1F	18042U	A	FULL	134/61	101/46	75	44.1/20	22.4/3.6	115V/60Hz/1	8.7-5.5	106/48	\$4.296

A = Air, W= Water Use Item # number when ordering

Shipping Weight: 123.5 Lbs. (56 Kg.)

NG 160

NG 160 A1H	17064U	A	HALF	152/69	128/58	150	44.1/20	22.2/4.5	115V/60Hz/1	6.78-5.2	106/48	\$4.908
NG 160 A1F	18064U	A	FULL	159/72	117/53	75	44.1/20	24.3/4.5	115V/60Hz/1	7.28-5.2	106/48	\$4.908

A = Air, W= Water Use Item # number when ordering

Shipping Weight: 123.5 Lbs. (56 Kg.)

NG 230

NG 230 A1H	17094U	A	HALF	231/105	176/80	240	77/35	25.4/7.1	115V/60Hz/1	5.28-5.2	141.10/64	\$5.281
NG 230 A1F	18094U	A	FULL	223/101	157/71	120	77/35	31/7.7	115V/60Hz/1	5.96-5.2	141.10/64	\$5.281

A = Air, W= Water Use Item # number when ordering

Shipping Weight: 167.55 Lbs. (76 Kg.)

NG 360

NG 360 A1H	17144U	A	HALF	342/155	293/133	288	99/45	22.1/10.6	115V/60Hz/1	6.10-8.9	163.14/74	\$5.893
NG 360 A1F	18144U	A	FULL	340/154	273/124	144	99/45	22.8/9.9	115V/60Hz/1	6.37-8.9	163.14/74	\$5.893

A = Air, W= Water Use Item # number when ordering

Shipping Weight: 187.40 Lbs. (85 Kg.)

SPIKA Modular



Half dice
1/2" x 1"
1.25 x 2.5 cm



Full dice
1" x 1"
2.5 x 2.5 cm

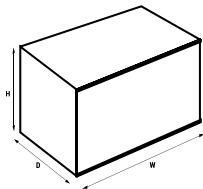

SPIKA MS 400-22			SPIKA MS 500			SPIKA MS 700-22			SPIKA MS 1000		
W	D	H	W	D	H	W	D	H	W	D	H
22"	24.41"	25.95"	29.92"	24.41"	19.69"	22"	24.41"	25.95"	29.92"	24.41"	29.92"
55.9 cm	62 cm	65.9 cm	76 cm	62 cm	50 cm	55.9 cm	62 cm	65.9 cm	76 cm	62 cm	76 cm
Fuse size 16			Fuse size 16			Fuse size 16			Fuse size 16		

Please, refer to the bin's section to ascertain information as to the correct bin for your ice maker. •Water cooled units available special order only. *Special order only.

ITEM #	COND. UNIT	CUBE STYLE	DAILY PRODUCTION LBS./KG		CUBES CYCLE	WATER USAGE GAL./100LBS. / L./HR.	VOLTAGE	KWH/100 LBS. - AMPS.	NET WEIGHT. LBS./ KG.	LIST PRICE	
			70°F - 50°F 90°F - 70°F	21°C - 10°C 32°C - 21°C		90°F - 70°F					
MS 400-22											
MS 400-22 A1H	17507U	A	HALF	432/196	351/159	300	19.1/13.1	115V / 60Hz / I	5.90/8.8	143.3/65	\$6.549
MS 400-22 A1F	18507U	A	FULL	432/196	351/159	150	19.1/13.1	115V / 60Hz / I	5.90/8.8	143.3/65	\$6.549
A = Air, W= Water Use Item # number when ordering Shipping Weight: 180.78 Lbs. (82 Kg.)											
MS 500											
MS 500 A1H	17204U	A	HALF	480/218	333/153	400	13.6/10.70	115V/60Hz/1	5.25/8.80	187/85	\$6.566
MS 500 W1H•	17205	W	HALF	461/209	410/186	400	-	115V/60Hz/1	4.91/14.50	187/85	\$6.566
MS 500 A1F	18204U	A	FULL	480/218	333/153	200	13.6/10.70	115V/60Hz/1	5.25/8.80	187/85	\$6.566
MS 500 W1F•	18205	W	FULL	461/209	400/182	200	-	115V/60Hz/1	4.73/14.50	187/85	\$6.566
A = Air, W= Water Use Item # number when ordering Shipping Weight: 209.44 Lbs. (95 Kg.)											
MS 700-22											
MS 700-22 A1H	17504	A	HALF	668/303	553/251	480	16.4/17.4	115V/60Hz/1	6.73/14.50	155.21/70.4	\$7.613
MS 700-22 W1H•	17505	W	HALF	-	-	240	-	115V/60Hz/1	4.91/14.50	155.21/70.4	\$7.613
MS 700-22 A1F	18504	A	FULL	676/307	527/239	480	16.2/17.4	115V/60Hz/1	6.48/14.50	155.21/70.4	\$7.613
MS 700-22 W1F•	18505	W	FULL	-	-	240	-	115V/60Hz/1	4.73/14.50	155.21/70.4	\$7.613
MS 700-22 A2H*	17502	A	HALF	668/303	553/251	480	16.4/17.4	208-230V/60Hz/1	6.70/9.00	155.21/70.4	\$7.613
MS 700-22 W2H•	17503	W	HALF	-	-	240	-	208-230V/60Hz/1	4.90/9.00	155.21/70.4	\$7.613
MS 700-22 A2F*	18502	A	FULL	676/307	527/239	480	16.2/17.4	208-230V/60Hz/1	6.50/9.00	155.21/70.4	\$7.613
MS 700-22 W2F•	18503	W	FULL	-	-	240	-	208-230V/60Hz/1	4.70/9.00	155.21/70.4	\$7.613
A = Air, W= Water Use Item # number when ordering Shipping Weight: 180.78 Lbs. (82 Kg.)											
MS 1000											
MS 1000 A2H	17402	A	HALF	970/440	730/331	800	13.4/20.60	208-230V/60Hz/1	5.34/10.00	232/105	\$10.002
MS 1000 W2H•	17403	W	HALF	974/442	915/415	800	-	208-230V/60Hz/1	3.90/10.00	232/105	\$10.002
MS 1000 A2F	18402	A	FULL	970/440	730/331	400	13.4/20.60	208-230V/60Hz/1	5.40/10.00	232/105	\$10.002
MS 1000 W2F•	18403	W	FULL	974/442	915/415	400	-	208-230V/60Hz/1	3.94/10.00	232/105	\$10.002
A = Air, W= Water Use Item # number when ordering Shipping Weight: 277.79 Lbs. (126 Kg.)											

SPIKA Remote



Half dice
1/2" x 1"
1.25 x 2.5 cm



Full dice
1"x1"
2.5 x 2.5 cm

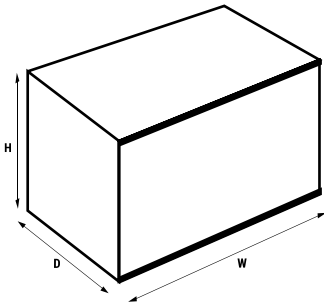

SPIKA MS 500-R		
W	D	H
29.93"	24.41"	19.69"
76 cm	62 cm	50 cm

Fuse Size 16



SPIKA MS 1000-R		
W	D	H
29.93"	24.41"	29.93"
76 cm	62 cm	76 cm

Fuse Size 16

Please, refer to the bin's section to ascertain information as to the correct bin for your ice maker.

ITEM #	COND. UNIT	CUBE STYLE	DAILY PRODUCTION LBS./KG 70°F - 50°F 90°F - 70°F 21°C - 10°C 32°C - 21°C		CUBES CYCLE	WATER USAGE GAL./100LBS. / L./HR. 90°F-70°F 70°F - 50°F		VOLTAGE	AMPS. A	NET WEIGHT. LBS./KG.	LIST PRICE
--------	------------	------------	---	--	-------------	---	--	---------	---------	----------------------	------------

MS 500R REMOTE / Split System

MS 500 A1HR	17214	A	HALF	441/200	440/199	400	15.2/10.1	2.9/10.8	115V/60Hz/1	10	165/75	\$6.752
MS 500 A1FR	18214	A	FULL	441/200	431/196	200	15.2/9.9	2.7/10.4	115V/60Hz/1	10	165/75	\$6.752

Use Item # number when ordering

Shipping Weight: 209 Lbs. (95 Kg.)

MS 1000R REMOTE / Split System

MS 1000 A2HR	17414	A	HALF	941/426	941/427	800	13.6/19.1	5.4/20.3	208-230V/60Hz/1	7.6	247/112	\$10.485
MS 1000 A2FR	18214	A	FULL	941/426	930/422	400	13.5/18.9	5.3/20.0	208-230V/60Hz/1	7.6	247/112	\$10.485

Use Item # number when ordering

Shipping Weight: 282 Lbs. (128 Kg.)

COMBINATION SPIKA + REMOTE CONDENSER

	RC5	RC10
SPIKA MS 500	●	
SPIKA MS 1000		●

REMOTE CONDENSERS



- Removes Heat from the Ice Making Area
- More Efficient Ice Making Operation

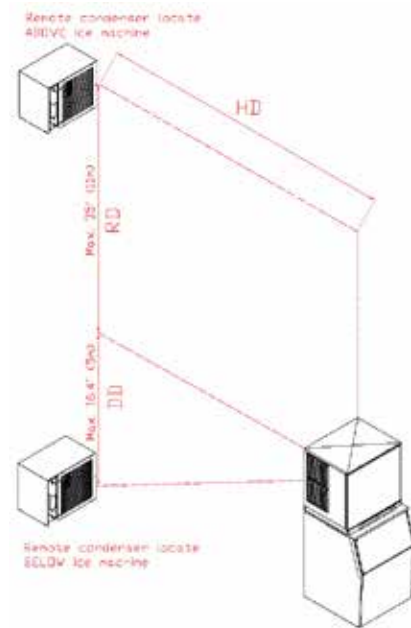

ITEM #	AMBIENT TEMPERATURE OPERATION RANGE (°F)	COOLING POWER (W) INC. TEMP. 15°C	VOLT / HZ / PH	AMPS. A	AIR FLOW m3/h	DIMENSIONS (Inch./cm.)			NET WEIGHT. LBS./ KG.	LIST PRICE
						WIDTH	DEPTH	HEIGHT		

REMOTE CONDENSER

RC5	17215	-20 - 120	4600	115/60/1	1.5	1100	26.8/68.1	16.8/42.7	16.4/41.7	55/25	\$2.186
RC10	17415	-20 - 120	9400	230/60/1	1	3000	29.4/74.6	16.8/42.7	22.3/56.6	88/40	\$2.379

Use Item # number when ordering

Shipping Weight RC5: 95 Lbs. (43 Kg.)

Shipping Weight RC10: 123 Lbs. (56 Kg.)

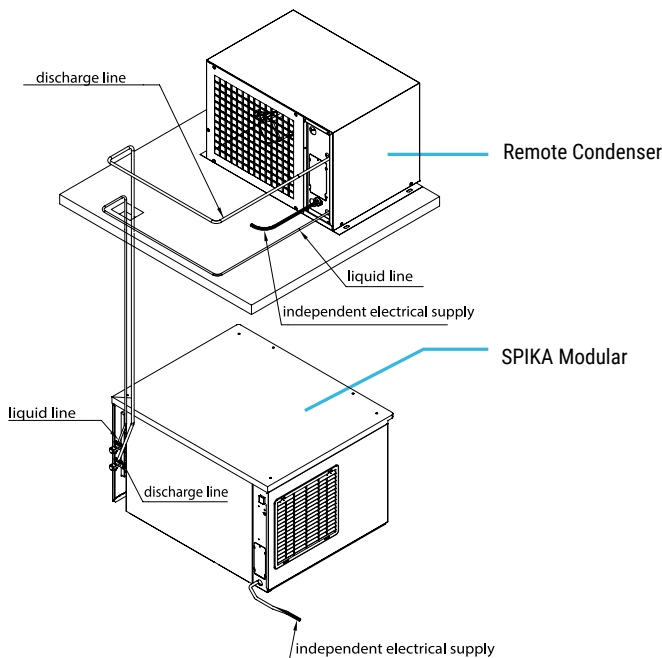

#ITEM	PRE-CHARGED LINE	PRICE
31061	KIT LINE SET MS500 20 ft	\$526
31064	KIT LINE SET MS500 35 ft	\$702
31065	KIT LINE SET MS500 50 ft	\$865
31066	KIT LINE SET MS1000 20 ft	\$526
31067	KIT LINE SET MS1000 35 ft	\$702
31068	KIT LINE SET MS1000 50 ft	\$865

HOTEL DISPENSERS

To fulfill the needs of the ice dispenser segment, ITV developed ice and water dispensers capable of dispensing either half or full dice, when complemented by our *SPIKA Modular Cube Series ice machines (MS 440, MS 500, MS 880 & MS 1000), priced separately.

3 YEARS WARRANTY PARTS & LABOR

Now you can choose from our two models, the DHD 200-30 with ice dispensing capacity or the DHD 200-30 W with ice and water dispensing capabilities. The best options for your hotel, convenience store, self-service, hospitals, schools, or where ever your guest requires ice around the clock. Just simply push the chute for easy ice dispensing.

Ergonomically designed by our team in order to accommodate different size hotel ice buckets, with easy use, to maintain and keep clean. ITV uses stainless steel AISI 304 cabinet, ensuring a perfect look after many years of ongoing use.



DHD 130-22		
W	D	H
22.05"	32.88"	50"
56 cm	83.5 cm	127 cm

DHD 200-30		
W	D	H
30.32"	32.88"	53.94"
77 cm	83.5 cm	137 cm

*Dimensions do not include adjustable legs from 6" (15.2 cm.) to 6.5" (16.5 cm.)

ITEM #	DESCRIPTION	STORAGE CAPACITY LBS./KG.	DISPENSING SPEED PER SECOND LBS./KG.	VOLTAGE	WATTS	AMPS.	NET WEIGHT. LBS./ KG.	SHIPPING WEIGHT LBS./KG.	LIST PRICE	
DHD 130-22										
DHD130-22	19320	ICE	127.9/58	0.24/0.109	115V/60Hz/1	210	1	161/73	181/82	\$6.097
DHD 130-22 W	19324	WATER & ICE	127.9/58	0.24/0.109	115V/60Hz/1	210	1	161/73	181/82	\$6.243

Use Item # number when ordering

DHD 200-30										
DHD 200-30	19302	ICE	183/83	0.24/0.109	115V/60Hz/1	195.5	1	192/87	244/111	\$6.624
DHD 200-30 W	19303	WATER & ICE	183/83	0.24/0.109	115V/60Hz/1	195.5	1	192/87	244/111	\$7.002

*Special order only. Use Item # number when ordering



DHD 200-30 & MS 500



DHD 200-30 & MS 1000



DHD 130-22 & MS 700-22

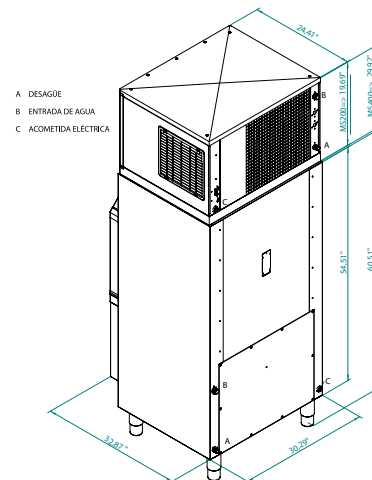

DELTA



Delta machines produce a large, crystal clear and gourmet cube, with a more modern truncated conical design that allows us to differentiate from the more classic "European" ice cubes.

These great ice cubes will offer a great option to savor your drinks, because they take longer to melt with its nonconventional larger shapes. They are the most desired ice cubes for hospitality professionals, mixologists and upscale minded consumers, ideal for the most discriminating in tastes for soft drinks and spirits.

The Delta range incorporates the new R290 gas cooling system, which improves machine efficiency and makes them more sustainable.

ITV's patented "Spray Bar Nozzles" with Horizontal Evaporator Plate design, force water to be sprayed up under pressure, avoiding trapped gases, and not allowing calcareous build-up. You achieve the most perfect, individual, transparent and crystal-clear ice cubes.

Delta Series are specially designed for small-space applications, such as bars, guest room floors, refreshment break areas, etc. You also save space, thanks to a front ventilation system, with easy accessibility for cleaning and servicing.



Horizontal Spray Bar Evaporator

**3 YEARS
WARRANTY
PARTS & LABOR**



Horizontal Spray Bar Evaporator

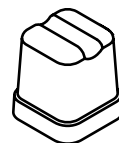

Delta cube
1.57" x 1.73"
4 x 4.4 cm



DELTA



NATURAL REFRIGERANT: Natural gas R290 with very low global warming potential which also reduces the energy consumption.



SPRAY SYSTEM (NOZZLES): The spray nozzle, patented by ITV, does not allow calcareous scale build-up and produces solid, individual, transparent ice cubes which take longer to melt.



DYNAMIC PRODUCTION: The water is constantly circulating and the ice gradually forms in thin layers, avoiding trapped gasses and producing crystal clear ice cubes. Only the purest of ice cubes are produced.



SILENT RAIN: All parts in contact with water have been designed to minimize their friction resulting in a very low noise level.



DUAL SWITCH: External switch allows to turn the machine on/off easily. Removing the top cover, we have the ice/ clean cycle switch on one side of the electrical box.



STRONG INOX FRAME. 304 STAINLESS STEEL CONSTRUCTION: Box-type frame with stainless steel supports, makes the machine stronger and allows servicing operation without disassembling the entire machine.



EASY ACCESS FOR SERVICE AND INSTALLATION: Designed to have better access to all components making installation and servicing operations easier. One person can disassemble the entire machine with a basic screwdriver.



FRONT VENTILATION: Condensing unit permits 100% front ventilation, air inflow and outflow through the front grill.



INSULATED STORAGE BIN: Storage bin with polyurethane foam insulation gives higher rigidity with lower heat transmission. Isolated but not refrigerated bins. Heavy duty door promotes longer ice storages, reducing melting.



OPERATING LIMITS: Tropicalized machines (Class T); Suitable for low temperature environments of 41° (5°C) Air and Water and high temperature environments of 109°F (43°C) (Air), 95°F (35°C) (Water) Water pressure: Min. 10 psi. (0.7 bar.)/ Max. 85 psi. (6 bar.). NOTE: Install a pressure reducer if water inlet pressure is more than 85 psi. (6 bar.).



ELECTRICAL SPECIFICATIONS: 115V/60Hz./1 - Fuse Size 15-20 - Nema Plug Type 5-15P.
Also available 208-230V/60Hz.- 220V/50Hz. NG 355—208-230V/60Hz./1. Also available 220V/50Hz. (Special order).



WARRANTY: 36 months parts and labor + 24 additional months parts on both compressor and evaporator.

DELTA

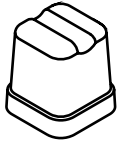

Delta cube
1.57" x 1.73"
4 x 4.4 cm

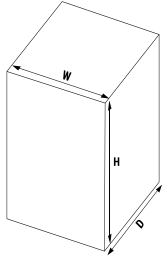

DELTA NG 80			DELTA NG 120			DELTA NG 150		
W	D	H	W	D	H	W	D	H
15.95"	20.28"	29.30"	15.95"	20.28"	29.30"	21.06"	23.43"	31.06"
40.5 cm	51.5 cm	74.4 cm	40.5 cm	51.5 cm	74.4 cm	53.5 cm	59.5 cm	78.9 cm

Fuse Size 10

Fuse Size 10

Fuse Size 10

* Dimensions do not include adjustable legs from 4" (10.2 cm.) to 6" (15.2 cm.)

ITEM #	COND. UNIT	DAILY PRODUCTION LBS./ KG 70°F - 50°F 90°F - 70°F 20°C - 10°C 32°C - 21°C	CUBES CYCLE	STORAGE LBS./ KG.	WATER USAGE GAL./100LBS. / L./HR 90°F - 70°F	VOLTAGE	AMPS. A	NET WEIGHT. LBS./ KG.	LIST PRICE
--------	------------	--	----------------	----------------------	--	---------	------------	-----------------------------	------------

DELTA NG 80

DELTA 80 A	14034U	A	77/35	64/29	18	33/15	33.3/3.1	115V/60Hz/1	10	84/38.11	\$4.935
------------	--------	---	-------	-------	----	-------	----------	-------------	----	----------	----------------

A = Air, W = Water

Use Item # number when ordering

Shipping Weight: 101 Lbs. (46 Kg.)

DELTA NG 120

DELTA 120 A	14044U	A	108/49	95/43	24	44/20	44.3/6.6	115V/60Hz/1	10	99/45	\$5.145
-------------	--------	---	--------	-------	----	-------	----------	-------------	----	-------	----------------

A = Air, W = Water

Use Item # number when ordering

Shipping Weight: 123 Lbs. (56 Kg.)

DELTA NG 150

DELTA 150 A	14054U	A	143/65	130/59	36	55/25	31.6/6.5	115V/60Hz/1	10	114/51.71	\$5.324
-------------	--------	---	--------	--------	----	-------	----------	-------------	----	-----------	----------------

A = Air, W = Water

Use Item # number when ordering

Shipping Weight: 149 Lbs. (68 Kg.)

IQ Nuggets



Ice Queen N machines produce ice nuggets, perfect for blends, as it gently mixes the flavors of the drink without watering it down.

Its moisture content (10%) and its compact texture allow it to keep drinks cold for longer. The main characteristic is its shape, halfway between an ice cube and crushed ice, although uniformly cut. It is hard on the inside and soft on the outside, and its use has been extended to cool, for example, fruit juices or yoghurts at food exhibitions.

The Ice Queen N range has a high efficiency evaporator, reducing the energy consumption while obtaining a greater production of ice. It also has a self diagnosis system with signaling LEDs to indicate the operation of the machine and alert to possible faults in order to be able to respond as quickly as possible. The body is made of AISI 304 stainless steel and has an on /off button for user convenience.

This is the new trend in hospitality. Crunchy ice that does not detract from the drink and that can be enjoyed in any leisure environment, as well as in the most select places.

**3 YEARS
WARRANTY
PARTS & LABOR**



STRONG MECHANICS: ITV's unique mechanical design is simple, strong and reliable. It will provide a longer life to your flaker, and shorten service times and costs; features oversized gearbox.



SECURITY CONTROLS: The machine is protected to avoid failures caused by gearbox motor temperature, water level, or ice level, includes a defrost time delay.



EASY ACCESS FOR SERVICE AND INSTALLATION: Designed to have better access to all components making installation and servicing operations easier. One person can disassemble the entire machine with a basic screwdriver.



OPERATING LIMITS: Tropicalized machines (Class T); Suitable for low temperature environments of 41° (5°C) Air and Water and high temperature environments of 109°F (43°C) (Air), 95°F (35°C) (Water) Water pressure: Min. 10 psi. (0.7 bar.)/ Max. 85 psi. (6 bar.)

NOTE: Install a pressure reducer if water inlet pressure is more than 85 psi. (6 bar.).



WARRANTY: 36 months parts and labor + 24 additional months parts on compressor, and 24 months parts on auger.



HEALTHCARE & RESEARCH: Hospitals, Laboratories, Universities.



SPORTS: Football, Basketball, Baseball, Athletics, Swimming, Soccer, Track & Field, Gymnastics, Traumas, Pre and Post Training, Spas, Sports Medical Facilities. Rest + Ice + Compression + Elevation = First Aid Method.



DRINKS: Soft drinks, Smoothies.



IQ Nuggets

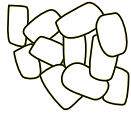

Nugget Type Ice

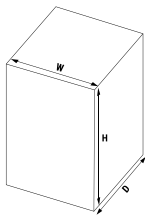

IQN 500			IQN 700			IQN 900			IQN 1200		
W	D	H	W	D	H	W	D	H	W	D	H
28"	29.7"	41"	22"	24.49"	28.03"	22"	24.49"	28.03"	22"	24.49"	28.03"
71.5 cm	70 cm	104.4 cm	55.9 cm	62.2 cm	71.2 cm	55.9 cm	62.2 cm	71.2 cm	55.9 cm	62.2 cm	71.2 cm

ITEM #	COND. UNIT	CUBE STYLE	DAILY PRODUCTION LBS. / KG 70°F - 50°F 90°F - 70°F 21°C - 10°C 32°C - 21°C	WATER USAGE GAL./100LBS. / L./HR 90°F - 70°F	VOLTAGE	AMPS.	NET WEIGHT. LBS./ KG.	LIST PRICE
IQN 500								
IQN 500 A	10576UN	A NUGGET	595/270	430/195	11.99/8.1	115V / 60Hz / I	10.2	222/101 \$12.075
A = Air, W = Water			Use Item # number when ordering			Shipping Weight: 218.26 Lbs. (99 Kg.)		
IQN 700								
IQN 700 A	10504UN	A NUGGET	714/324	579/263	11.99/13.5	115V / 60Hz / I	9	205/93 \$10.433
A = Air, W = Water			Use Item # number when ordering			Shipping Weight: 218.26 Lbs. (99 Kg.)		
IQN 900								
IQN 900 A	10502UN	A NUGGET	870/395	705/320	11.99/16.45	115V / 60Hz / I	10.5	205/93 \$11.635
A = Air, W = Water			Use Item # number when ordering			Shipping Weight: 218.26 Lbs. (99 Kg.)		
IQN 1200								
IQN 1200 A	10506UN	A NUGGET	1197/543	895/406	11.9/16.9	115V / 60Hz / I	8.7	205/93 \$13.230
A = Air, W = Water			Use Item # number when ordering			Shipping Weight: 218.26 Lbs. (99 Kg.)		

IQ Flakers

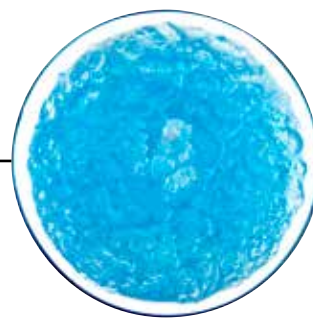

IQ Series of Flakers produces “dryer” and more compact ice flakes through its vertical cylindrical evaporator.

Whatever your requirements, you can find the perfect flaker to meet your needs. From 220 lbs. (100 kg.) to 360 lbs. (163 kg.) of daily ice production, under counter models are perfect for sushi displays, cocktail bars, health care facilities, laboratory testing, sport centers or spa applications because of their reduced space requirements.

Modular and Remote units, up to 2,860 lbs. (1298 kg.) of ice production per day are perfect for larger demands of ice such as super-markets, grocery stores, convenience stores, fisheries and marinas.

If the use of your flake ice is for displaying, this is perfect fit for any shape of showcase. If for cocktails or smoothies, you achieve rapidly chilled beverages to enhance the refreshment of your drink.



ITV's Patented Auger with 5 years parts warranty

**3 YEARS
WARRANTY
PARTS & LABOR**



Dryer Type Ice



IQ Flakers



STRONG MECHANICS: ITV's unique mechanical design is simple, strong and reliable. It will provide a longer life to your flaker, and shorten service times and costs; features oversized gearbox.



SECURITY CONTROLS: The machine is protected to avoid failures caused by gearbox motor temperature, water level, or ice level, includes a defrost time delay.



EASY ACCESS FOR SERVICE AND INSTALLATION: Designed to have better access to all components making installation and servicing operations easier. One person can disassemble the entire machine with a basic screwdriver.



OPERATING LIMITS: Tropicalized machines (Class T); Suitable for low temperature environments of 41° (5°C) Air and Water and high temperature environments of 109°F (43°C) (Air), 95°F (35°C) (Water) Water pressure: Min. 10 psi. (0.7 bar.)/ Max. 85 psi. (6 bar.)

NOTE: Install a pressure reducer if water inlet pressure is more than 85 psi. (6 bar.).



ELECTRICAL SPECIFICATIONS: General—115V/60Hz./1 - Fuse Size 10-20 - Nema Plug Type 5-15P. Also available 208-230V/60Hz - 220V/50Hz. IQ 900 & IQ 1300—208-230V/60Hz./1. Also available three phase. IQ2700 & Remote Units—208-230V/60Hz./3. (Special order on certain units)



WARRANTY: 36 months parts and labor + 24 additional months parts on compressor, and 24 months parts on auger.

FLAKE ICE: Humidity 50-60%. The best ice for so many applications.



SEAFOOD: Supermarkets, Fisheries, Fish Shops, Seafood Restaurants, Boating, Marinas.



HEALTHCARE & RESEARCH: Hospitals, Laboratories, Universities.



SPORTS: Football, Basketball, Baseball, Athletics, Swimming, Soccer, Track & Field, Gymnastics, Traumas, Pre and Post Training, Spas, Sports Medical Facilities. Rest + Ice + Compression + Elevation = First Aid Method.



DRINKS: Soft drinks, Smoothies.

IQ Flaker with built-in bin



Dryer Type Ice

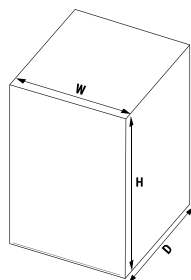

IQ 200 C		
W	D	H
18.51"	23.63"	30.71"
47 cm	60 cm	78 cm



IQ 300 C Comprises ice maker head on storage bin (ship in 2 units)

IQ 300 C		
W	D	H
20.48"	21.66"	53.55"
52 cm	55 cm	136 cm

* Dimensions do not include adjustable legs from 4" (10.2 cm.) to 6" (15.2 cm.)
 • Water cooled units available special order only. Fuse Size 10

ITEM #	COND. UNIT	CUBE STYLE	DAILY PRODUCTION		STORAGE	WATER USAGE		VOLTAGE	AMPS.	NET WEIGHT.	LIST PRICE
			LBS./ KG			GAL./100LBS. / L./HR					

IQ 200 C

IQ 200 C A	10214	A	FLAKE	220/100	140/64	44/20	12.0/4.2	115V/60Hz/1	5.5	128/58	\$6,995
IQ 200 C W•	10215	W	FLAKE	225/102	145/66	44/20	-	115V/60Hz/1	5	128/58	\$6,995

A = Air, W = Water

Use Item # number when ordering

Shipping Weight: 169 Lbs. (77 Kg.)

IQ 300 C

IQ 300 C A	10104	A	FLAKE	360/163	260/118	132/60	11.9/6.8	208-230V/60Hz/1	7	165/75	\$8,164
IQ 300 C W•	10105	W	FLAKE	365/166	265/120	132/60	-	208-230V/60Hz/1	6.5	165/75	\$8,164

A = Air, W = Water

Use Item # number when ordering

Shipping Weight: 253 Lbs. (115 Kg.)

IQ Modular



IQ 300			IQ 500			IQ 900			IQ 1300			IQ 2700		
W	D	H	W	D	H	W	D	H	W	D	H	W	D	H
20.47"	21.65"	19.30"	20.47"	21.65"	22.84"	26.77"	21.65"	26.38"	26.38"	21.65"	31.50"	52.76"	24.02"	32.29"
52 cm	55 cm	49 cm	52 cm	55 cm	58 cm	68 cm	55 cm	67 cm	67 cm	55 cm	80 cm	134 cm	61 cm	82 cm

• Water cooled units available special order only. Fuse Size 10, except IQ 1300 208-230V/60Hz/1 Fuse Size 15 and IQ 2700 Fuse Size 20
Please, refer to the bin's section on pages 22-24, to ascertain information as to the correct bin for your machine.

ITEM #	COND. UNIT	CUBE STYLE	DAILY PRODUCTION LBS./KG 70°F - 50°F 90°F - 70°F 21°C - 10°C 32°C - 21°C	WATER USAGE GAL./100LBS. / L./HR 90°F - 70°F	VOLTAGE	AMPS.	NET WEIGHT. LBS./KG.	LIST PRICE
--------	------------	------------	---	---	---------	-------	-------------------------	------------

IQ 300

IQ 300 A	10114	A	FLAKE	360/163	260/118	11.9/6.8	115V/60Hz/1	7	108/49	\$7.723
IQ 300 W•	10115	W	FLAKE	365/166	265/120	-	115V/60Hz/1	6.5	108/49	\$7.723

A = Air, W = Water Use Item # number when ordering

Shipping Weight: 156 Lbs. (71 Kg.)

IQ 500

IQ 500 A	10124	A	FLAKE	675/306	485/220	12.0/12.8	115V/60Hz/1	9	115/52	\$8.450
IQ 500 W•	10125	W	FLAKE	685/311	495/225	-	115V/60Hz/1	8.5	115/52	\$8.450

A = Air, W = Water Use Item # number when ordering

Shipping Weight: 156 Lbs. (71 Kg.)

IQ 900

IQ 900 A	10132	A	FLAKE	980/445	710/322	11.9/18.5	208-230V/60Hz/1	9.5	181/82	\$11.130
IQ 900 W•	10133	W	FLAKE	1005/456	730/331	-	208-230V/60Hz/1	9	181/82	\$11.130
IQ 900 A III	10142	A	FLAKE	980/445	710/322	11.9/18.5	208-230V/60Hz/3	6	181/82	\$11.130
IQ 900 W III•	10143	W	FLAKE	1005/456	730/331	-	208-230V/60Hz/3	5.5	181/82	\$11.130

A = Air, W = Water Use Item # number when ordering

Shipping Weight: 286 Lbs. (130 Kg.)

IQ 1300

IQ 1300 A	10154	A	FLAKE	1430/649	1030/467	11.9/27.0	208-230V/60Hz/1	12.5	231/105	\$13.252
IQ 1300 W•	10155	W	FLAKE	1450/658	1050/476	-	208-230V/60Hz/1	11.5	231/105	\$13.252
IQ 1300 A III	10162	A	FLAKE	1430/649	1030/467	11.9/27.0	208-230V/60Hz/3	7.5	231/105	\$13.252
IQ 1300 W III•	10163	W	FLAKE	1450/658	1050/476	-	208-230V/60Hz/3	7	231/105	\$13.252

A = Air, W = Water Use Item # number when ordering

Shipping Weight: 322 Lbs. (146 Kg.)

IQ 2700

IQ 2700 A	10172	A	FLAKE	2860/1298	2060/935	11.9/54.1	208-230V/60Hz/3	15	463/210	\$24.922
IQ 2700 W•	10173	W	FLAKE	2900/1316	2100/953	-	208-230V/60Hz/3	14	463/210	\$24.922

A = Air, W = Water Use Item # number when ordering

Shipping Weight: 608 Lbs. (276 Kg.)

IQ F



Flakes Type Ice

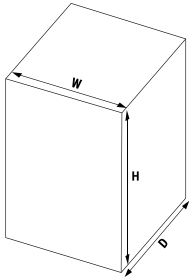

IQF 700			IQF 900			IQN 1200		
W	D	H	W	D	H	W	D	H
22"	24.49"	28.03"	22"	24.49"	28.03"	22"	24.49"	28.03"
55.9 cm	62.2 cm	71.2 cm	55.9 cm	62.2 cm	71.2 cm	55.9 cm	62.2 cm	71.2 cm

ITEM #	COND. UNIT	CUBE STYLE	DAILY PRODUCTION LBS./KG 70°F - 50°F 90°F - 70°F 21°C - 10°C 32°C - 21°C	WATER USAGE GAL./100LBS. / L./HR 90°F - 70°F	VOLTAGE	AMPS.	NET WEIGHT. LBS./KG.	LIST PRICE		
IQF 700										
IQF 700 A	10504UF	A	FLAKE	770/350	634/288	11.99/14.6	115V / 60Hz / I	9	205/93	\$10.433
A = Air, W = Water			Use Item # number when ordering			Shipping Weight: 218.26 Lbs. (99 Kg.)				
IQF 900										
IQF 900 A	10502UF	A	FLAKE	925/420	749/340	11.99/17.5	115V / 60Hz / I	10.5	205/93	\$11.635
A = Air, W = Water			Use Item # number when ordering			Shipping Weight: 218.26 Lbs. (99 Kg.)				
IQF 1200										
IQF 1200 A	10506UF	A	FLAKE	1197/543	895/406	11.9/16.9	115V / 60Hz / I	8.7	205/93	\$13.230
A = Air, W = Water			Use Item # number when ordering			Shipping Weight: 218.26 Lbs. (99 Kg.)				

IQ Split / Low Side Remote



Dryer Type Ice

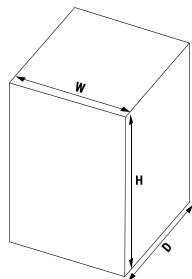

IQ 1300 R		
W	D	H
20.87"	16.14"	32.29"
53 cm	41 cm	82 cm



IQ 2700 R		
W	D	H
31.10"	20.08"	32.29"
79 cm	51 cm	82 cm

Refrigerant R-404. Fuse Size 10. Remote Cooled units are only composed of the evaporator, compressor and condenser not included.

ITEM #	COND. UNIT	ICE FORM	DAILY PRODUCTION LBS./ KG 70°F - 50°F 90°F - 70°F 21°C - 10°C 32°C - 21°C	WATER USAGE GAL./100LBS. / L./HR 90°F - 70°F	COOL.REQ. WATTS. / BTU/HR.	VOLTAGE	AMPS.	NET WEIGHT. LBS./ KG.	LIST PRICE
--------	------------	----------	---	---	----------------------------	---------	-------	-----------------------	------------

IQ 1300 R

IQ 1300 R	10181	REMOTE	FLAKE	1430/649	1030/467	11.9/27.0	3000/10245	208-230V/60Hz/3	2.5	154/70	\$11.064
-----------	-------	--------	-------	----------	----------	-----------	------------	-----------------	-----	--------	-----------------

A = Air, W = Water Use Item # number when ordering

Shipping Weight: 236 Lbs. (107 Kg.)

IQ 2700 R

IQ 2700 R	10194	REMOTE	FLAKE	2860/1298	2060/935	11.9/54.1	6000/20490	208-230V/60Hz/3	5	308/140	\$20.788
-----------	-------	--------	-------	-----------	----------	-----------	------------	-----------------	---	---------	-----------------

A = Air, W = Water Use Item # number when ordering

Shipping Weight: 368 Lbs. (167 Kg.)



SEAFOOD DISPLAY



SUSHI DISPLAY



COCKTAIL BARS



HEALTHCARE & TRAUMA CENTER

STORAGE BINS

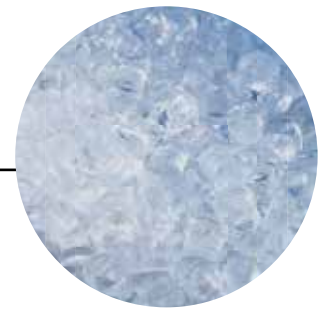

In order to complement your ice production needs. ITV has the right selection of ice storage bins for your modular and remote unit requirements.

Bins are ideal for storing ice where and when you need it; isolated, but not refrigerated, ITV's ice storage bins will provide you always fresh ice, because of the heavy duty sealed door and a low drain, through which melted water exits.

With heavy duty stainless steel construction, non-corroding polyethylene lined walls, and gravity loading ice, ITV's bins are stronger, more durable, and the right choice to meet your ice storage needs. Our bins have a one piece high impact resistant rotocast liner, with no corners, easy to clean and maintain.

The body of the slope front bins models are made of 304 Stainless Steel construction and they include a custom cut, top-fixed adapter plate, for the specific size of any ITV machine, with four stainless steel adjustable legs, and one ice scoop.

**3 YEARS
WARRANTY
PARTS & LABOR**



SPIKA & IQ ice machines sold separately.



SLOPE FRONT BINS



S-300			S-400-22			S-500			S-750			S-900			S-1050		
W	D	H	W	D	H	W	D	H	W	D	H	W	D	H	W	D	H
29.92"	32.25"	29.41"	22"	34.33"	44.17"	30"	32.29"	42.17"	42.13"	32.29"	42.17"	48.03"	32.29"	42.17"	52.01"	34.33"	44.17"
76 cm	81.9 cm	74.7 cm	55.9 cm	87.2 cm	112.2 cm	76.2 cm	82 cm	107.1 cm	107 cm	82 cm	107.1 cm	122 cm	82 cm	107.1 cm	132.1 cm	87.2 cm	112.2 cm

* Dimensions do not include adjustable legs from 6" (15.2 cm.) to 6.5" (16.2 cm.)

*Slope front bins include adapter plates suited for 30" wide machines. Please refer to the chart below for alternate adapter plate part numbers.

ITEM #	STORAGE CAPACITY		NET WEIGHT LBS./ KG.	SHIPPING WEIGHT LBS./ KG.	LIST PRICE	
	**AHRI LBS./ KG.	APPLICATION LBS./ KG.				
ICE STORAGE BIN SERIES						
S-300	19570	282/128	353/160	103/47	117/53	\$2.252
S-400-22	19560	320/145	400/181	119/54	145/66	\$2.397
S-500	19500	408/185	510/231	123/56	185/84	\$2.602
S-750	19510	594/269	742/337	152/69	233/106	\$3.281
S-900	19520	686/311	858/389	165/75	249/113	\$3.546
S-1050	19531	838.4/380	1,048/475	207/94	300/136	\$4.093
ICE BAGGER	32178	8.8/4 per bag		12.9/5.85	15.4/7	\$781

**AHRI storage capacity represents the 80% of total volume x 30 Lbs./ft3 average density of ice.

MACHINE/BIN SIZING CHART		S-300	S-400	S-500	S-750	S-900	S-1050
SPIKA SERIES	MS 400-22	★	★	★	★	★	◇
	MS 500	★		★	★	★	◇
	MS 700-22	★	★	★	★	★	◇
	MS 1000	★		★	★	★	★
IQ SERIES	IQ 300	★	★	★	◇	◇	◇
	IQ 500	★	★	★	★	◇	◇
	IQN/IQF 700	★	★	★	★	★	◇
	IQN/IQF 900	★	★	★	★	★	◇
	IQ 900	★	◇	★	★	★	★
	IQ 1300	★	◇	★	★	★	★
	**IQ 2700						★
	IQ 1300 R	★		★	★	★	★
	IQ 2700 R	◇		★	★	★	★

★ Recommended ◇ Compatible ** Note: Machine width 52" Ice Storage Bin width "48

Item Number	Adapter Plate	List Price
32925	ADAPTER PLATE BIN S300 MS22	\$398
31829	ADAPTER PLATE BIN S500 MS22	\$398
31830	ADAPTER PLATE BIN S750 MS22	\$431
31832	ADAPTER PLATE BIN S900 MS22	\$465
31834	ADAPTER PLATE BIN S1050 MS22	\$531

Ice Storage Bin includes cube style (Spika MS) adaptor plate. Please, specify if flaker style (IQ) adaptor plate is required, when ordering.

ICE TRANSPORT SYSTEM - Single Cart



6 Buckets
Buckets sold separately

SCS-350			SCS-700		
W	D	H	W	D	H
30"	40"	51.97"	30"	40"	73.23"
76.2 cm	101.6 cm	132 cm	76.2 cm	101.6 cm	186 cm

*** Ice Storage Bin includes IQ style adaptor plate.**
Please, specify if cuber style (SPIKA) adaptor plate is required, when ordering. (Listed below).

EC-250		
W	D	H
24.49"	41.50"	28.43"
62.2 cm	105.4 cm	72.2 cm

ITEM #	STORAGE CAPACITY		NET WEIGHT LBS./ KG.	SHIPPING WEIGHT LBS./ KG.	LIST PRICE
	**AHRI LBS./ KG.	APPLICATION LBS./ KG.			

ICE STORAGE BIN WITH CARTS SERIES

SCS-350	19660	242.5/110	308.6/140	165/75	181/82	\$10.033
SCS-700	19655	533/240	661.4/300	209/95	225/102	\$11.185

AHRI storage capacity represents the 80% of total volume x 30 Lbs./ft3 average density of iceBased on "Ice Managed" full Bin.

** Based on "Ice Managed" full Bin.

CART & BUCKETS SYSTEM

EASY CART EC-250	19551	197/88.8	247/111	77/35	106/4	\$2.420
SET OF 6 BUCKETS	30501	123.2/56	154/70	-	-	\$765

		S-750	S-900
SPIKA SERIES	MS 400-22	★	★
	MS 500	★	★
	MS 700-22	★	★
	MS 1000	★	★
IQ SERIES	IQ 300	★	◇
	IQ 500	★	★
	IQN/IQF 700	★	★
	IQN/IQF 900	★	★
	IQ 900	★	★
	IQ 1300	★	★
	**IQ 2700		
	IQ 1300 R	★	★
	IQ 2700 R		

- Stainless steel body AISI 304 with galvanized back and bottom.
- Hard sanitary polyethylene liner, resistant to blows, friction or scratches.
- EASY CLEANING DESIGN: Seamless one-piece vat with rounded corners, keeping all points clean.
- The paddle is included to manage the ice easily. Drainage system which collects and channels the water from the drainpipe of the carts cleanly and without pools.
- EASY CART is made of sanitary polyethylene without roughness to facilitate cleaning.
- EASY CART is ergonomic and easy to move with little effort.
- EASY CART has a braking, drainage system and cover.
- Optional buckets system is for distributing ice quickly and effortlessly.
- Warranty: 36 months parts and labor.

★ Recommended ◇ Compatible



Paddle is included

***Ice Storage Bin includes IQ style adaptor plate.**

Please, specify if cuber style (SPIKA) adaptor plate is required, when ordering.

Item Number	Adapter Plate	Price List
31320	IQ MODULAR	\$620
31189	SPIKA MODULAR	\$620
31433	22" SPIKA MODULAR	\$620
Item Number	Top detachable panel	Price List
31190	IQ & SPIKA MODULAR	\$202

ICE TRANSPORT SYSTEM - Double Cart



6 Buckets
Buckets sold separately

SCD-900			SCD-1400			SCD-1800			EC-250		
W	D	H	W	D	H	W	D	H	W	D	H
60"	40"	59.84"	60"	40"	71.65"	60"	40"	82.05"	24.49"	41.50"	28.43"
152.4 cm	101.6 cm	152 cm	152.4 cm	101.6 cm	182 cm	152.4 cm	101.6 cm	208.4 cm	62.2 cm	105.4 cm	72.2 cm

*Ice Storage Bin includes IQ style adaptor plate. Please, specify if cuber style (SPIKA) adaptor plate is required, when ordering. (Listed below).

ITEM #	STORAGE CAPACITY		NET WEIGHT LBS./ KG.	SHIPPING WEIGHT LBS./ KG.	LIST PRICE
	**AHRI LBS./ KG.	APPLICATION LBS./ KG.			

ICE STORAGE BIN WITH CARTS SERIES

SCD-900	19702	728/330	911/413	381/140	538/235	\$16.113
SCD-1400	19703	1,089/494	1,360/617	353/160	562/255	\$19.757
SCD-1800	19701	1,433/650	1,790/812	386/175	608/276	\$22.001

AHRI storage capacity represents the 80% of total volume x 30 Lbs./ft3 average density of iceBased on "Ice Managed" full Bin.

** Based on "Ice Managed" full Bin.

CART & BUCKETS SYSTEM

EASY CART EC-250	19551	197/88.8	247/111	77/35	106/4	\$2.420
SET OF 6 BUCKETS	30501	123.2/56	154/70	-	-	\$765

		SCD-900	SCD-1350	SCD-1800
SPIKA SERIES	MS 400-22	★	◇	◇
	MS 500	★	◇	◇
	MS 700-22	★	◇	◇
	MS 1000	★	★	◇
IQ SERIES	IQ 300	◇	◇	◇
	IQ 500	★	◇	◇
	IQ 900	★	★	★
	IQ 1300	★	★	★
	**IQ 2700	★	★	★
	IQ 1300 R	★	★	★
	IQ 2700 R	★	★	★

- Stainless steel body AISI 304 with galvanized back and bottom.
- Hard sanitary polyethylene liner, resistant to blows, friction or scratches.
- EASY CLEANING DESIGN: Seamless one-piece vat with rounded corners, keeping all points clean.
- The paddle is included to manage the ice easily. Drainage system which collects and channels the water from the drainpipe of the carts cleanly and without pools.
- EASY CART is made of sanitary polyethylene without roughness to facilitate cleaning.
- EASY CART is ergonomic and easy to move with little effort.
- EASY CART has a braking, drainage system and cover.
- Optional buckets system is for distributing ice quickly and effortlessly.
- Warranty: 36 months parts and labor.

★ Recommended ◇ Compatible



Paddle is included

*Ice Storage Bin includes IQ style adaptor plate.

Please, specify if cuber style (SPIKA) adaptor plate is required, when ordering.

Item Number	Adapter Plate	Price List
30296	IQ MODULAR	\$772
8753	SPIKA MODULAR	\$772
Item Number	Top detachable panel	Price List
30297	IQ MODULAR	\$455
30443	SPIKA MODULAR	\$455

WATER FILTRATION & CLEANING

WATER FILTERS AND REPLACEMENT CARTRIDGES

Water quality plays a serious and important role in health and food service. Not only does water quality determine the taste and quality of all beverages served, it also has a dramatic effect on equipment effectiveness, maintenance costs and equipment longevity.

ITV Water Filtration Kits provide high water quality by removing sediments, found in most water supplies contributing to cloudy ice and equipment issues, and chlorine, which imparts an unpleasant taste and odor in water, reducing the quality of beverages served. It means, attaining better ice and beverage quality, lower equipment maintenance cost, and a lower and more effective operation.

ITV's Water Filtration Systems also address the first cause of equipment issues-mineral scale deposits, that decrease daily ice production and greatly increase equipment maintenance costs.

ITV filters deliver a specially formulated scale control product that is proven most effective in controlling mineral scale, especially in high water hardness environments. Unlike most competitive systems, ITV's scale control product is also delivered at a consistent rate ensuring predictable periods of mineral scale control resulting in mineral scale protection for entire time between filter replacements.

Single Kits include single head with bracket, and Twin Kits include a manifold with pressure gauge and one 1/2" plastic ball valve. Both Kits are available in the 10" (CS-10) or 16" (CS-11) cartridges depending on the ice machine's daily production.



	CS-10	CS-11	CS-101 K	CS-111 K	CS-102 K	CS-112 K
Rated Capacity Gal./ l.	10,000/37,900	15,000/56,850	10,000/37,900	15,000/56,850	20,000/75,800	30,000/113,700
Rated Service Flow Rate gpm./ cfs.	1.75/0.003	2.00/0.004	1.75/0.003	2.00/0.004	3.50/0.007	4.00/0.008
Oper. Pressure Min. - Max. psi./bar.	20-125/1.4-8.6	20-125/1.4-8.6	20-125/1.4-8.6	20-125/1.4-8.6	20-125/1.4-8.6	20-125/1.4-8.6
Oper. Temperature Min. - Max. °F/°C	35-100°F / 1.5-38°C	35-100°F / 1.5-38°C	35-100°F / 1.5-38°C	35-100°F / 1.5-38°C	35-100°F / 1.5-38°C	35-100°F / 1.5-38°C
Conn. Size Inch./mm.	REPLACEMENT CARTRIDGE	REPLACEMENT CARTRIDGE	3/8" / 94	3/8" / 94	1/2" / 125	1/2" / 125
Replacement Cartridge			CS-10	CS-11	(2) CS-10	(2) CS-11
List Price	\$157	\$194	\$394	\$460	\$908	\$1.004

SCALE CLEANER

		CS 101 K	CS 111 K	CS 102 K	CS 112 K
SPIKA SERIES	NG 130; NG 160; NG 230	★			
	NG 360		★		
	MS 400-22			★	
	MS 700-22			★	
	MS 1000				★
IQ SERIES	IQ 200 C				
	IQ 300 C; IQ 300		★		
	IQ 500			★	
	IQ 900; IQ 1300; IQ 2700				★
	IQ 1300 R; IQ 2700 R				★



	1.8oz BAG	7oz BAG
#Item	1420	4033
Indicated to	All ice machines up to 132 lbs/24h	All ice machines from 132 lbs/24h
List Price	\$36	\$48

INSTALLATION GUIDELINES

- The ice maker should be installed in accordance with applicable national, state, and local regulations.
- Be sure to remove all packing material and supports, especially from the evaporator area.
- The machine must be installed “indoors” WITHIN A CONTROLLED ENVIRONMENT and should not be located next to or near high heat producing equipment or where air inflow is limited.
- A minimum of 6” of space is required on both sides, back, top as well as below the machine to ensure proper ventilation. Do not place anything on top of the ice maker or facing the front grill and do not sit machine directly onto floor. Legs must be installed to allow proper ventilation.
- Check that the voltage is the same as on the nameplate before connecting the unit. The ice maker needs to be connected to a dedicated grounded electrical circuit that is individually fused. Utilization of an extension cord, adapter plug, or multi-outlet extension cord WILL VOID manufacturer warranty.
- Water supply should be a minimum of 10 psi. (0.7 bar) and a maximum of 85 psi. (6 bar.). Do not connect the machine to a hot water supply.
- Connect the machine to a standard commercial water filter or “whole house” water system, as required by ITV warranty.
- Maintenance issues resulting in reduces or non-functioning of the machines are the responsibility of end-user.
- Drainage is gravity fed. Pipes should be at least 6” (15 cm) below the drain of the ice maker if possible. If not, a condensation pump should be utilized for proper drainage of the machine.
- Please, refer to the user’s manual supplied with the machine for detailed information on the installation, startup, use and maintenance of the equipment, otherwise, ITV reserves the right to void the warranty.
- For immediate assistance, do not hesitate to contact our service staff, eastern daylight/standard time, by calling ITV’s toll free number +1-888 ITV 1 ICE (+1-888 488 1423), or by e-mail: service@itvice.com. Visit our website www.itvice.com for further information about ITV’s authorized service agencies throughout the U.S. and Canada.

ICE USAGE GUIDE

FOOD SERVICE

RESTAURANT	1.5 lbs. (0.7 kg.) per person
COCKTAIL	3 lbs. (1.4 kg.) per person/seat
WATER GLASS	4 oz. (115 grs.) per 10 oz. (300 ml.) glass
SALAD BAR	40 lbs. (18 kg.) per cubic foot
FAST FOOD	5 oz. (140 grs.) per 8.5 oz. (250 ml.) drink
	8 oz. (225 grs.) per 14 oz. (400 ml.) drink
	12 oz. (340 grs.) per 21oz. (600 ml.) drink

LODGING

GUEST ICE	5 lbs. (2.3 kg.) per room
RESTAURANT	1.5 lbs. (0.7 kg.) per person
COCKTAIL	3 lbs. (1.4 kg.) per person/ seat
CATERING	1 lbs. (0.45 kg.) per person

HEALTHCARE

PATIENT ICE	10 lbs. (4.5 kg.) per bed
CAFETERIA	1 lbs. (0.45 kg.) per person

CONVENIENCE STORE

BEVERAGE	6 oz. (170 grs.) per 12 oz. (350 ml.) drink
	10 oz. (280 grs.) per 20 oz. (590 ml.) drink
	16 oz. (450 grs.) per 32 oz. (950 ml.) drink
COLD PLATE	50% more ice per day
PACKAGED ICE	Lbs. per bag per units sold each day

BEVERAGE SERVICE

DRINKS	40% ice per drink per drinks/day
---------------	----------------------------------

ITV Ice Makers

Environmental action plan

“Green” Campaign

As one of the world's leading ice machine manufacturers, ITV, projects a moral responsibility to show the way to a better, more durable environment. When you buy one of our machines, you're buying a machine that has been manufactured in a sustainable process with green ecological energy, like no other manufacturer does.

This fact sheet summarizes some of the actions we have been taking for many years.

In addition to meeting all major international standards and approvals, we have focused on quality icemakers delivering the highest output at the lowest environmental requirements.

The most “visual” effort, has been the implementation of the unique energy auto efficiency manufacturing company. For more than 10 years our production has been “powered” by solar energy, to the extent that we have become an energy supplier for neighboring area companies.

Other continuous efforts are made in the following areas:

- The Recycling of oil and refrigerant gases.
- The Recycling of all debris and waste.
- The Recycling of used water of any kind.
- On a regular basis we evaluate the carbon impact of all our activities. This systematic approach leads to even more efficient use of all resources.

We encourage each, and every one to adopt the same approach to improve and enhance our environment.



NOTES

DISTRIBUTION CENTERS

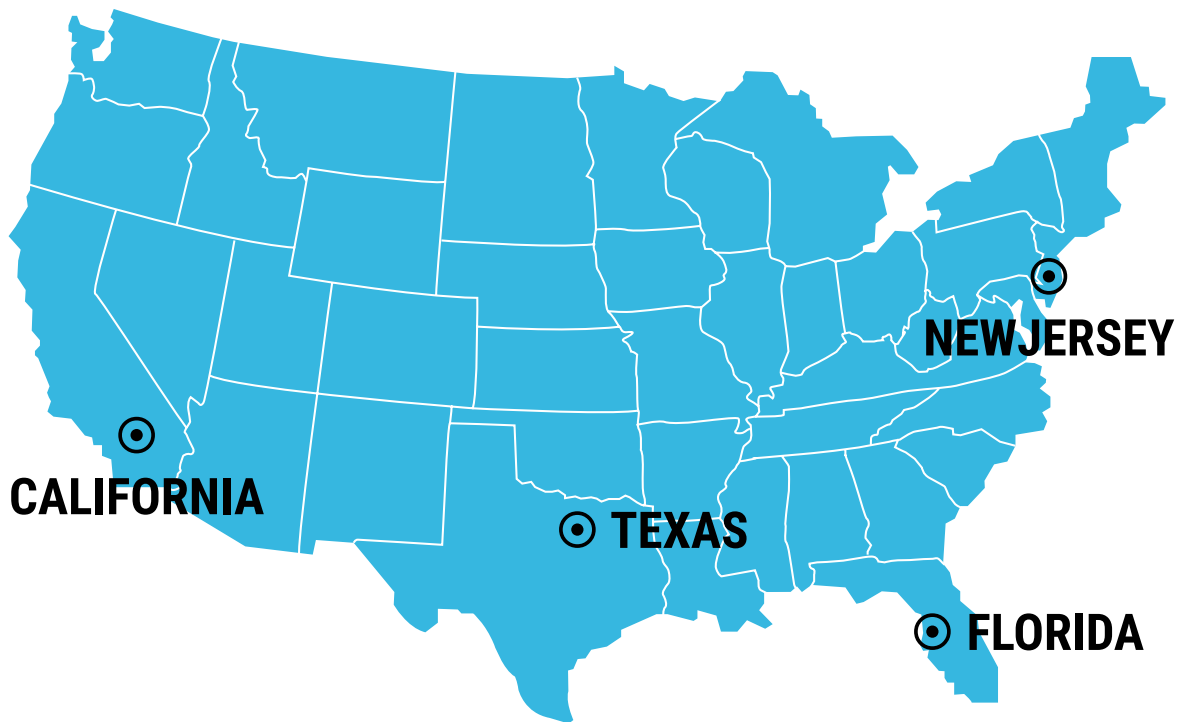

ITV Ice Makers Inc.

9550 Satellite Blvd, Suite 100
Orlando, FL 32837

Phone: 1 407 826 1860

Fax: 1 407 826 1861

Toll Free: 1 888 488 1423

admin@itvice.com

service@itvice.com

ITV | ICE makers 

ITV Ice Makers Inc.

9550 Satellite Blvd, Suite 100
Orlando, FL 32837

Phone: 1 407 826 1860

Fax: 1 407 826 1861

Toll Free: 1 888 488 1423

www.itvice.com | sales@itvice.com

C/49081-05/H/22_v3