



PREMIUM

# Blending Equipment

---

U.S. Product Catalog









# SMARTER Investment

You only want the best in your kitchen, behind your counter, and for your customers. You won't accept anything less—not from yourself, and not from the equipment you count on, every day, to perform. That's why chefs and foodservice professionals trust Vitamix. They know it's not just a blender; it's an essential part of their success.



# Table of Contents

---

4.	<a href="#"><u>Commercial Products</u></a>	
8.	<a href="#"><u>Covered Beverage Blenders</u></a>	
12.	<a href="#"><u>Uncovered Beverage Blenders</u></a>	
16.	<a href="#"><u>Food Preparation Blenders</u></a>	
22.	<a href="#"><u>Frozen Treat Mixers</u></a>	
26.	<a href="#"><u>Containers</u></a>	
38.	<a href="#"><u>Accessories &amp; Parts</u></a>	
47.	<a href="#"><u>Ordering Information</u></a>	



COMMERCIAL  
**Products**

---

Food or beverage, front of house or back, there's a Vitamix machine to suit your menu and your batch sizes. And now, finding the right machine has never been easier. We've divided our machines into categories according to application, so you can quickly identify which product might be right for your business.



## COVERED BEVERAGE BLENDERS

Reduce blending noise for superior customer experience

---

Up to 34 recipe programs to automate blending

---

Advance Containers offer maximum efficiency and dripless spouts

---

To view machines, refer to the Covered Beverage Blenders section



## UNCOVERED BEVERAGE BLENDERS

Variety of control options and container sizes to choose from

---

Up to 6 optimized programs with automatic shut-off

---

Recommended for a wide range of blends, from smoothies to frozen drinks to açai bowls

---

To view machines, refer to the Uncovered Beverage Blenders section



## FOOD PREP BLENDERS

Powerful efficiency to shorten prep times in Back of House (BOH) applications

---

Variable Speed Control achieves precise textures in every dish

---

Tamper allows continuous blending and tackles dense ingredients

---

To view machines, refer to the Food Preparation Blenders section



## FROZEN TREAT MIXERS

Incorporate mix-ins into frozen desserts

---

Standard or programmed models available

---

Variety of agitators to choose from

---

To view machines, refer to the Frozen Treat Mixers section



# Explore what we can do together



*Technique:*

## BLENDING

The speed of the Vitamix blades fully incorporates ingredients, including ice and frozen fruits, for signature, hand-crafted blends. Depending on your machine's controls, use pre-programmed settings to achieve consistent results, or 93 variable speeds to adjust the mouthfeel of every drink.



*Technique:*

## CHOPPING

Using the Pulse or On/Off switch, you can deliver a few quick bursts of power to rough chop ingredients, creating chunky dips and sauces without knife work. Instead of a food processor with limited controls, a Vitamix blender gives you a full range of speeds to refine the size of every chop.



*Technique:*

## HEATING

With the Vitamix machine's ability to heat ingredients through friction, soups and sauces can typically be brought to 170°F in just 5 minutes of blending on High. Use that power to your advantage when creating delicate custards and sauces, instead of risking scorching them in a double boiler.



*Technique:*

## HOMOGENIZING

Frozen ingredients are quickly homogenized in the container's vortex, with no chunks left behind. Vitamix machines allow you to create a wide range of recipes that would otherwise be too time-consuming, since you can blend house-made desserts in a single process and serve immediately.



*Technique:*

## GRINDING

Grind and pulverize virtually any ingredient to create every menu item from scratch without added oil, sugar, or shelf stabilizers. Transform roasted nuts to perfectly smooth butter and freeze-dried berries to the lightest powders — a wide variety of textures that just aren't possible with another appliance.



*Technique:*

## EMULSIFYING

By pouring oil slowly through the lid plug opening, emulsifications are created in seconds. Even new prep cooks can master this technique to create simple vinaigrettes, hollandaise sauce, and more.



*Technique:*  
**CREAMING**

Creating fluffy, creamy textures in your Vitamix container will save your pastry chef time and money. There's no need to sift ingredients—the blender's speed breaks up clumps and fully incorporates ingredients for perfect creamed recipes.



*Technique:*  
**PURÉEING**

In a single process, the Vitamix blender delivers exceptional texture and flavor refinement that typically requires additional steps like straining through a chinois. Easily adjust speed to control mouthfeel and create everything from a textured dip to a silky smooth purée.



*Technique:*  
**INFUSING**

Take handcrafted cocktails to the next level by creating your own flavored simple syrups, right in the blender. Just add mint, citrus zest, or spices to your simple syrup made in the blender and pulse a few times to marry the flavors.



*Technique:*  
**MUDDLING**

Let your Vitamix blender do the prep work for you. Pulsing lets you quickly rough chop items like fresh herbs to release their essential oils and create a great muddled drink. Add the perfect finishing touch by grinding your own sugar or salt for distinctive glass rims.



*Technique:*  
**WHIPPING**

Blend heavy cream with chosen flavorings (such as mint or chocolate) on high speed until soft peaks form. Or create an indulgent mousse as your main dessert course by whipping the cream and folding in flavorings that have been blended separately.



*Technique:*  
**WHOLE JUICING**

For smoothie and juice bars, a fresh juice blend is packed with flavor. And Vitamix blends the whole ingredient — for more fiber and less waste. Simply blend fruit and vegetable ingredients with water to your desired consistency. These fresh juices are also a great addition to your bar and restaurant menus.





COVERED BEVERAGE

# Blenders

---





<b>THE QUIET ONE®</b>	<b>TOUCH &amp; GO ADVANCE</b>
-----------------------	-------------------------------

*Our quietest blender, most trusted  
by the world's largest chains*

*Noise reduction for  
smaller volume shops*

<b><i>Applications</i></b>	Ideal for double and triple batches of smoothies, frappes, juices, milkshakes, and cocktails	Ideal for any blended beverage, including smoothies, frappes, juices, milkshakes, and cocktails
<b><i>Motor</i></b>	≈ 3 hp	≈ 2.3 hp
<b><i>Included Container</i></b>	48-ounce Advance Container with Advance blade	32-ounce Advance Container with Advance blade
<b><i>Controls</i></b>	34 pre-programmed recipe settings to customize your 6-button control panel	20 pre-programmed recipe settings to customize your 6-button control panel
<b><i>Automated Processing</i></b>		
<b><i>Programmable</i></b>	Programmable with kit (sold separately)	
<b><i>Speeds</i></b>	93 variable speeds allow flexibility during manual processing	
<b><i>Pulse</i></b>	High/Low Pulse	High/Low Pulse
<b><i>Accessories</i></b>	48- or 32-ounce Advance Containers 48- or 32-ounce Standard Containers 32-ounce Aerating Container	32-ounce Advance Containers 32-ounce Aerating Container 48- or 32-ounce Standard Containers

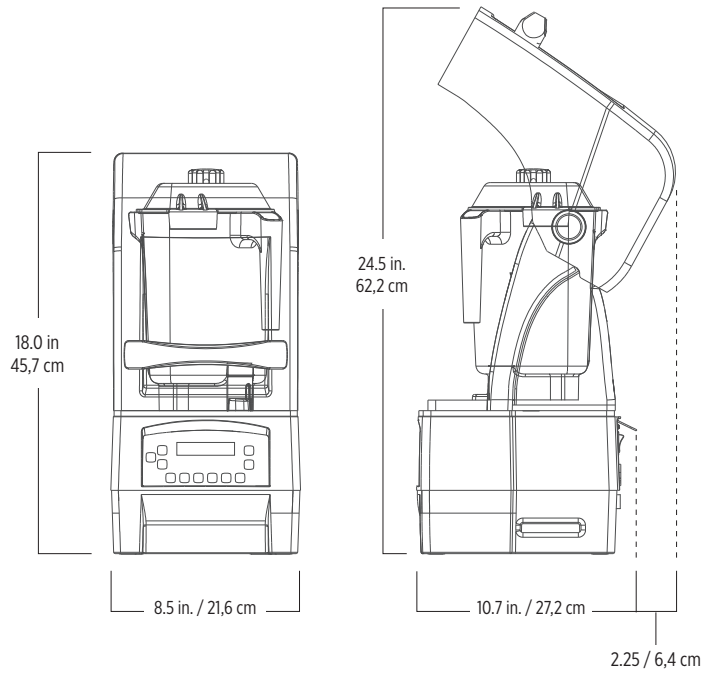

ITEM / MODEL #	DESCRIPTION	LIST PRICE
36019 / VM0145	<p><b>The Quiet One with 48 oz. / 1,4 L</b> BPA-Free, clear / stackable. Advance Container complete with Advance blade assembly and lid, removable compact twist lock cover, and 34 programs</p>	\$2,529.30

**SPECIFICATIONS:**

**Programs:** 34

**Motor:** ≈ 3 peak output horsepower motor

**Electrical:** 120 V, 50/60 Hz, 15.0 A

**Container & Blade:** 48 oz. / 1,4 L container complete with Advance blade assembly and lid

**Dimensions:** (H x W x D):  
18.0 x 8.5 x 10.7 in. / 45,7 x 21,6 x 27,2 cm  
*Height with lid open:* 24.5 in. / 62,2 cm

**Certifications:** 

**SHIPPING:**

**Pack:** 1 per standard pack

**Carton Dimensions:** (H x W x D):  
19.37 x 11.87 x 13 in. / 49,21 x 30,16 x 33,02 cm

**Weight:** 23.1 lbs.

**Case Cube:** 2.3 cu. ft. / 0,07 cu. m

**WARRANTY:** The Quiet One is backed by a three-year warranty on motor base parts and a one-year warranty on labor. For more complete warranty terms and conditions, please call 1.800.437.4654 or visit vitamix.com.

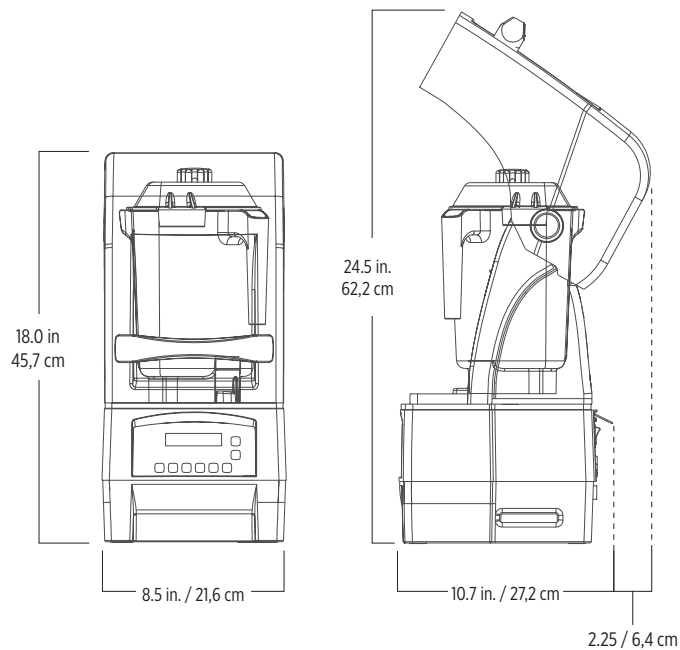

ITEM / MODEL #	DESCRIPTION	LIST PRICE
068255 / VM0115A	<b>Touch &amp; Go Advance with 32 oz. / 0,9 L</b> BPA-Free, clear / stackable Advance Container complete with Advance blade assembly and lid, and removable compact twist lock cover*, and 20 programs	\$1,881.22

**SPECIFICATIONS:****Programs:** 20**Motor:** ≈2.3 peak output horsepower motor**Electrical:** 120 V, 50/60 Hz, 12.0 A**Container & Blade:** 32 oz. / 0,9 L container complete with Advance blade assembly and lid**Dimensions:** (H x W x D):

18.0 x 8.5 x 10.8 in / 45,7 x 21,6 x 27,3 cm

*Height with lid open:* 24.5 in / 62,2 cm**Certifications:** **SHIPPING:****Pack:** 1 per standard pack**Carton Dimensions:** (H x W x D):

19.37 x 11.87 x 13.0 in / 49,21 x 30,16 x 33,02 cm

**Weight:** 23.1 lbs.**Case Cube:** 2.3 cu. ft. / 0,1 cu. m**WARRANTY:** The Touch & Go Advance is backed by a three-year warranty on motor base parts and a one-year warranty on labor. For more complete warranty terms and conditions, please call 1.800.437.4654 or visit [vitamix.com](http://vitamix.com).



UNCOVERED BEVERAGE

# Blenders

---





DRINK MACHINE™ ADVANCE®	DRINK MACHINE™ TWO-SPEED
-------------------------	--------------------------

*Six blending programs offer custom capabilities for every menu*

*Easy-to-use controls for consistent drink quality*

<b><i>Applications</i></b>	Ideal for any blended beverage, including smoothies, frappés, juices, milkshakes, and cocktails	Ideal for açai bowls, sorbets, and green smoothies
<b><i>Motor</i></b>	≈ 2.3 hp	≈ 2.3 hp
<b><i>Included Container</i></b>	48-ounce Advance Container with Advance blade	64-ounce Standard Container with wet blade
<b><i>Tamper</i></b>		Tamper
<b><i>Controls</i></b> <b><i>Automated Processing</i></b>	6 programs deliver fast and consistent high-quality beverages	
<b><i>Programmable</i></b>	Programmable with kit (sold separately)	
<b><i>Speeds</i></b>		High / Low
<b><i>Pulse</i></b>	Pulse	
<b><i>Accessories</i></b>	48- or 32-ounce Advance Containers 48- or 32-ounce Standard Containers	64 ounce Standard Containers 48- or 32-ounce Standard Containers

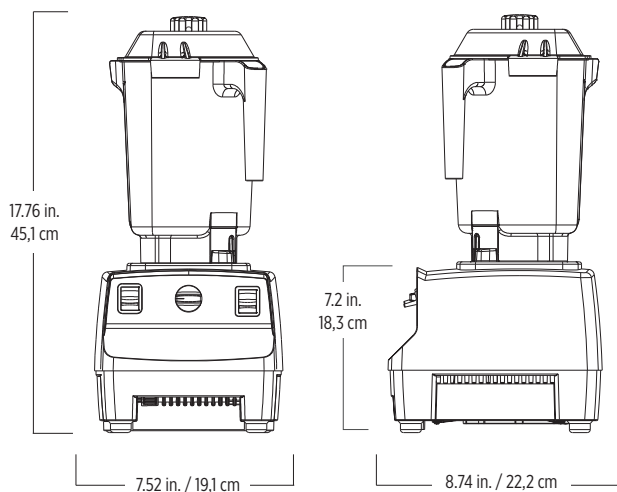

ITEM / MODEL #	DESCRIPTION	LIST PRICE
62824 / VM0100A	<b>Drink Machine Advance with BLACK base, 48 oz. / 1,4 L</b> BPA-Free clear/stackable Advance Container complete with Advance blade assembly and lid. Includes 6 pre-loaded programs.	\$1,037.37
62825 / VM0100A	<b>Drink Machine Advance with RED base, 48 oz. / 1,4 L</b> BPA-Free, clear / stackable Advance Container complete with Advance blade assembly and lid. Includes 6 pre-loaded programs.	\$1,037.37

**SPECIFICATIONS:**

**Programs:** 6

**Motor:** ≈2.3 peak output horsepower motor

**Electrical:** 120 V, 50/60 Hz, 11.5 A

**Container & Blade:** 48 oz. / 1,4 L container complete with Advance blade assembly and lid

**Dimensions:** (H x W x D):  
17.76 x 7.52 x 8.74 in / 45,1 x 19,1 x 22,2 cm

**Certifications:** UL NSF

**SHIPPING:**

**Pack:** 1 per standard pack

**Carton Dimensions:** (H x W x D):  
13.1 x 11.9 x 16.9 in. / 33,3 x 30,2 x 42,9 cm

**Weight:** 13.54 lbs.

**Case Cube:** 1.5 cu. ft. / 0,04 cu. m

**WARRANTY:** The Drink Machine Advance is backed by a three-year warranty on motor base parts and a one-year warranty on labor. For more complete warranty terms and conditions, please call 1.800.437.4654 or visit vitamix.com.

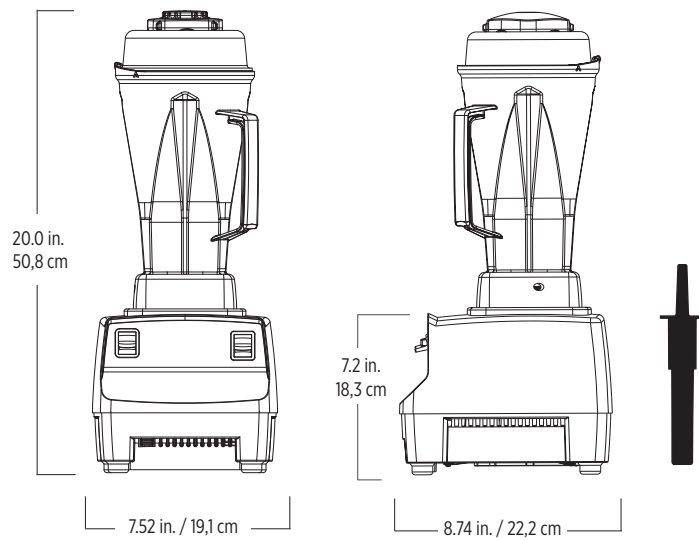

ITEM / MODEL #	DESCRIPTION	LIST PRICE
62828 / VM0100	<b>Drink Machine Two-Speed with 64 oz. / 2,0 L</b> BPA-Free, clear standard container complete with wet blade assembly and lid, tamper, and black base.	\$819.34

**SPECIFICATIONS:**

**Motor:** ≈2.3 peak output horsepower motor

**Electrical:** 120 V, 50/60 Hz, 11.5 A

**Container & Blade:** 64 oz. / 2,0 L standard container complete with wet blade assembly and lid

**Dimensions:** (H x W x D):  
20.0 x 7.52 x 8.74 in / 50,8 x 19,1 x 22,2 cm

**Certifications:** 

**SHIPPING:**

**Pack:** 1 per standard pack

**Carton Dimensions:** (H x W x D):  
3.1 x 11.9 x 16.9 in. / 33,3 x 30,2 x 42,9 cm

**Weight:** 11.0 lbs.

**Case Cube:** 1.5 cu. ft. / 0,04 cu. m

**WARRANTY:** The Drink Machine Two-Speed is backed by a three-year warranty on motor base parts and a one-year warranty on labor. For more complete warranty terms and conditions, please call 1.800.437.4654 or visit vitamix.com.



FOOD PREP

# Blenders

---





VITA-PREP® 3

VITA-PREP®

VITAMIX XL®

*Exceptional power, versatility, and performance for the most demanding kitchens*

*Dependable BOH tool to simplify prep work*

*Our most powerful, largest capacity machine for maximum efficiency*

<b>Applications</b>	For difficult back-to-back blending, chopping, puréeing, emulsifying, heating, grinding	Blending, chopping, puréeing, emulsifying, heating, grinding	Large-volume batches, ground proteins, ice cream and gelato bases, aerated batters and whipped creams, dressings and vinaigrettes
<b>Motor</b>	≈3 hp and larger cooling fan	≈2.3 hp	≈4.2 hp
<b>Included Container</b>	64-ounce Standard Container with wet blade	64-ounce Standard Container with wet blade	1.5-gallon XL Container with XL blade and 64-ounce XL Container with XL blade  Also available in a 1.5 g container only package
<b>Tamper</b>	Tamper	Tamper	Tamper
<b>Controls</b>	Variable Speed Control	Variable Speed Control	Variable Speed Control Model and Programs Model available
<b>Variable Speeds</b>			
<b>Pulse</b>			Pulse
<b>Accessories</b>	64-, 48- or 32-ounce Standard Containers 32-ounce Aerating Container	64-, 48- or 32-ounce Standard Containers 32-ounce Aerating Container	1.5 g XL Container 64 ounce XL Container

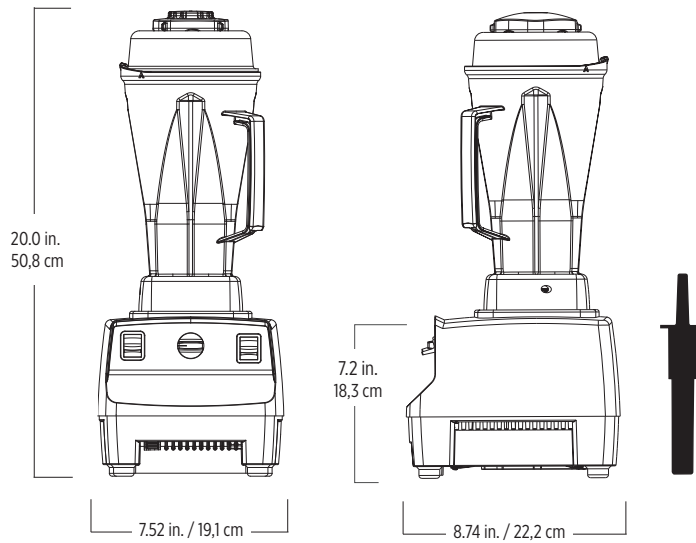

ITEM / MODEL #	DESCRIPTION	LIST PRICE
62826 / VM0101D	<b>Vita-Prep 3 with 64 oz. / 2,0 L</b> BPA-Free, clear container complete with wet blade assembly, lid, tamper, and black base.	\$1,180.63

**SPECIFICATIONS:**

**Motor:** ≈3 peak output horsepower motor

**Electrical:** 120 V, 50/60 Hz, 13 A

**Container & Blade:** 64 oz. / 2,0 L container complete with wet blade assembly and lid

**Dimensions:** (H x W x D):  
20.0 x 7.52 x 8.74 in / 50,8 x 19,1 x 22,2 cm

**Certifications:** 

**SHIPPING:**

**Pack:** 1 per standard pack

**Carton Dimensions:** (H x W x D):  
13.1 x 11.9 x 16.9 in. / 33,3 x 30,2 x 42,9 cm

**Weight:** 13.8 lbs.

**Case Cube:** 1.5 cu. ft. / 0,04 cu. m

**WARRANTY:** The Vita-Prep 3 is backed by a three-year warranty on motor base parts and a one-year warranty on labor. For more complete warranty terms and conditions, please call 1.800.437.4654 or visit vitamix.com.

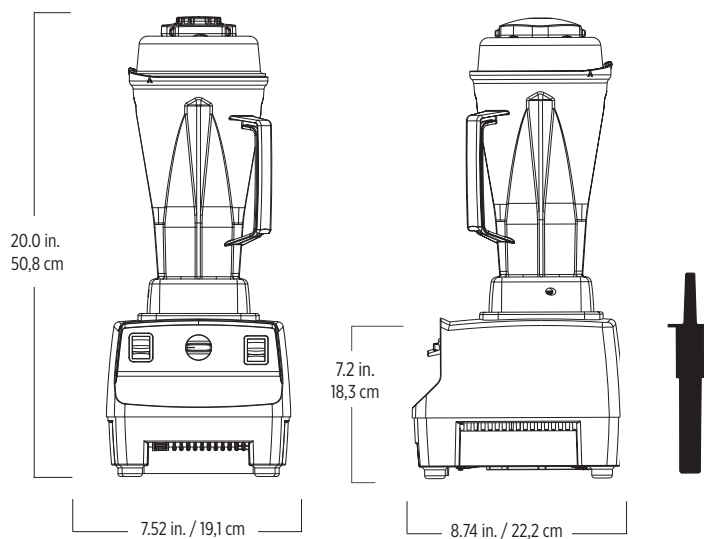

ITEM / MODEL #	DESCRIPTION	LIST PRICE
62827 / VM0101	<b>Vita-Prep with 64 oz. / 2,0 L</b> BPA-Free, clear container complete with wet blade assembly, lid, tamper, and black base	\$921.53

**SPECIFICATIONS:**

**Motor:** ≈2.3 peak output horsepower motor

**Electrical:** 120 V, 50/60 Hz, 11.5 A

**Container & Blade:** 64 oz. / 2,0 L container complete with wet blade assembly and lid

**Dimensions:** (H x W x D):  
20.0 x 7.52 x 8.74 in / 50,8 x 19,1 x 22,2 cm

**Certifications:** eULus NSF

**SHIPPING:**

**Pack:** 1 per standard pack

**Carton Dimensions:** (H x W x D):  
13.1 x 11.9 x 16.9 in. / 33,3 x 30,2 x 42,9 cm

**Weight:** 13.8 lbs.

**Case Cube:** 1.5 cu. ft. / 0,04 cu. m

**WARRANTY:** The Vita-Prep is backed by a three-year warranty on motor base parts and a one-year warranty on labor. For more complete warranty terms and conditions, please call 1.800.437.4654 or visit vitamix.com.

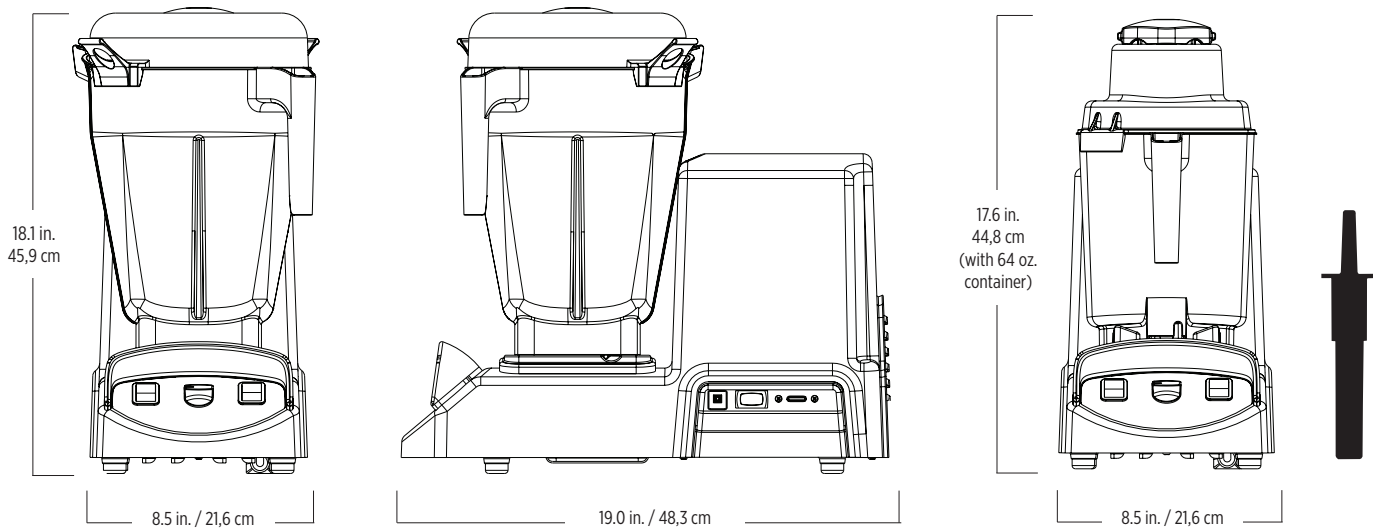

ITEM / MODEL #	DESCRIPTION	LIST PRICE
5201 / VM0141A	<b>Vitamix XL Variable Speed with 1.5 gal. / 5,6 L</b> container complete with XL blade assembly, lid, and tamper. Also includes <b>64 oz. / 2,0 L</b> container complete with XL blade assembly and lid.	\$3,832.63
5205 / VM0141A	<b>Vitamix XL Variable Speed with 1.5 gal. / 5,6 L</b> container complete with blade assembly, lid, and tamper.	\$3,578.86

**SPECIFICATIONS:**

**Motor:** ≈4.2 peak output horsepower motor

**Electrical:** 120 V, 50/60 Hz, 15.0 A

**Container & Blade:** 1.5 gal. / 5,6 L and 64 oz. / 2,0 L high-impact clear / stackable container complete with XL blade assembly and lid

**Dimensions:** (H x W x D):  
18.1 x 8.5 x 19.0 in. / 45,9 x 21,6 x 48,3 cm

**Certifications:** cULus NSF

**SHIPPING:**

**Pack:** 1 per standard pack

**Carton Dimensions:** (H x W x D):  
18.5 x 15.8 x 35.5 in. / 47,0 x 40,0 x 90,0 cm

**Weight:** 45.5 lbs.

**Case Cube:** 6.0 cu. ft. / 0,17 cu. m

**WARRANTY:** The Vitamix XL is backed by a three-year warranty on motor base parts and a one-year warranty on labor. For more complete warranty terms and conditions, please call 1.800.437.4654 or visit vitamix.com.



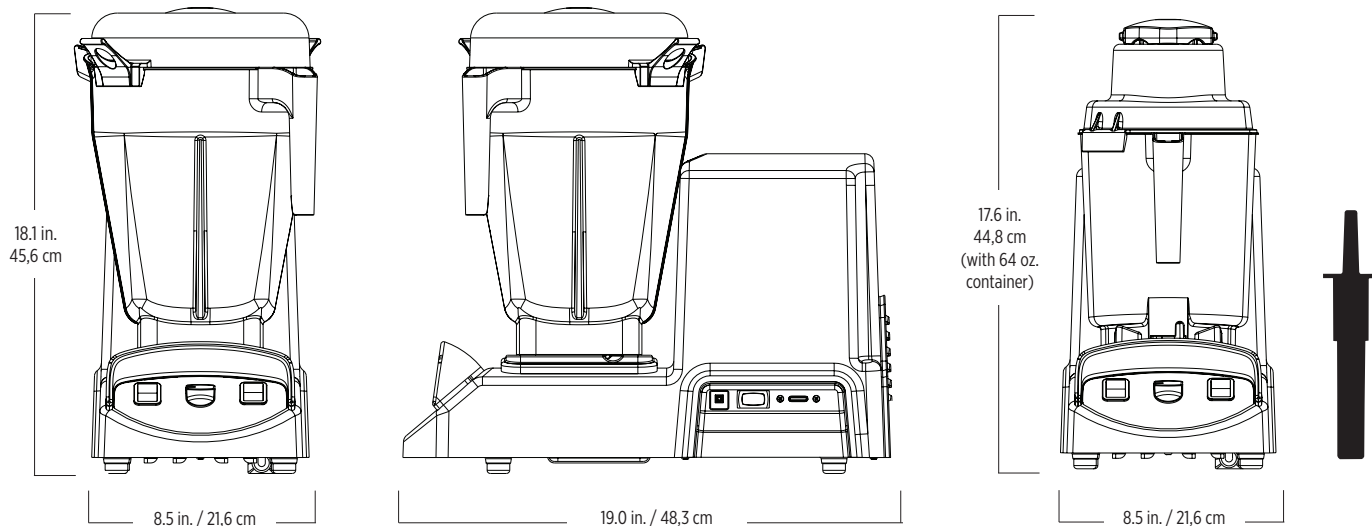

ITEM / MODEL #	DESCRIPTION	LIST PRICE
5202 / VM0141	<b>Vitamix XL Programs with 1.5 gal. / 5,6 L container</b> complete with XL blade assembly, lid, and tamper. Also includes <b>64 oz. / 2,0 L container</b> complete with XL blade assembly, and lid. Includes 6 - preloaded programs.	\$3,832.63

**SPECIFICATIONS:**

**Programs:** 6

**Motor:** ≈4.2 peak output horsepower motor

**Electrical:** 120 V, 50/60 Hz, 15.0 A

**Container & Blade:** 1.5 gal. / 5,6 L and 64 oz. / 2,0 L high-impact clear / stackable container complete with XL blade assembly and lid

**Dimensions:** (H x W x D):  
18.1 x 8.5 x 19.0 in. / 45,9 x 21,6 x 48,3 cm

**Certifications:** 

**SHIPPING:**

**Pack:** 1 per standard pack

**Carton Dimensions:** (H x W x D):  
18.5 x 15.8 x 35.5 in. / 47,0 x 40,0 x 90,0 cm

**Weight:** 45.5 lbs.

**Case Cube:** 6.0 cu. ft. / 0,17 cu. m

**WARRANTY:** The Vitamix XL is backed by a three-year warranty on motor base parts and a one-year warranty on labor. For more complete warranty terms and conditions, please call 1.800.437.4654 or visit vitamix.com.



FROZEN TREAT

# Mixers

---



MIX'N MACHINE® ADVANCE®

MIX'N MACHINE®

*Programmed incorporating of mix-ins into ice cream and frozen yogurt*

*Standard incorporating of mix-ins into ice cream and frozen yogurt*

<b><i>Applications</i></b>	Frozen desserts with mix-ins	Frozen desserts with mix-ins
<b><i>Motor</i></b>	500 - 3000 RPM	3440 RPM
<b><i>Included Container</i></b>	N/A	N/A
<b><i>Controls</i></b> <b><i>Automated Processing</i></b>	6 programmed settings with gradual acceleration	
<b><i>Activation</i></b> <b><i>Pulse</i></b>	Cup-activated lever Pulse	On/ Off Switch
<b><i>Accessories</i></b>	Variety of agitators available for different applications	Variety of agitators available for different applications

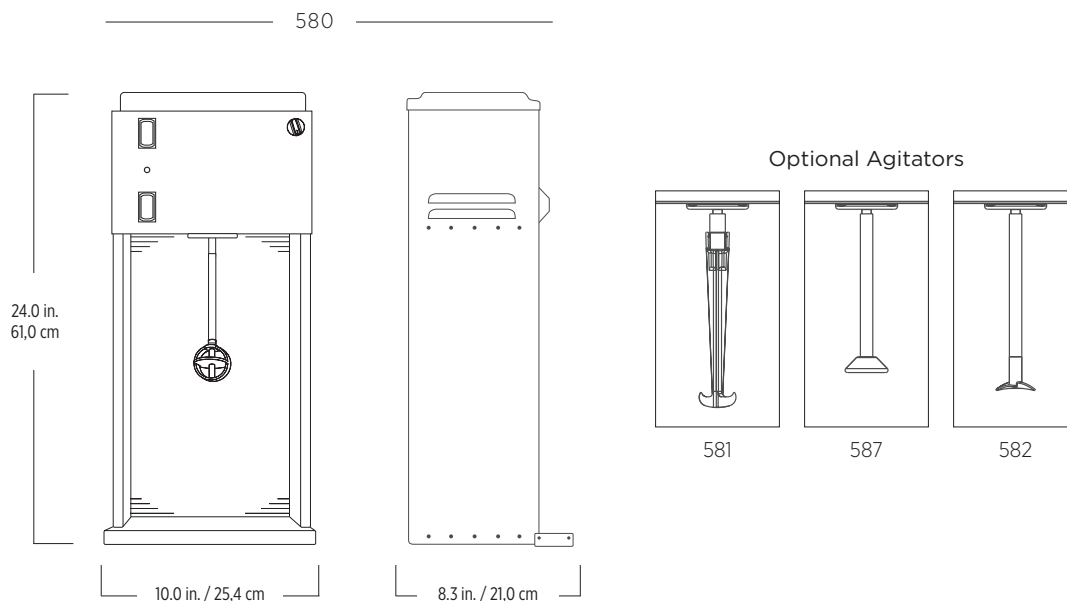

ITEM / MODEL #	DESCRIPTION	LIST PRICE
580 / VM0805B	<b>Mix'n Machine Advance</b> with permanent soft ice cream agitator. Includes 6 pre-loaded programs.	\$1,953.87
581 / VM0805B	<b>Mix'n Machine Advance</b> with removable / reusable agitator, includes 10 removable agitators. Includes 6 pre-loaded programs.	\$1,974.20
582 / VM0805B	<b>Mix'n Machine Advance</b> with aggressive / permanent hard ice cream agitator. Includes 6 pre-loaded programs.	\$2,003.18
587 / VM0805B	<b>Mix'n Machine Advance</b> with permanent soft ice cream cone-shaped agitator. Includes 6 pre-loaded programs.	\$2,003.18

**SPECIFICATIONS:**

**Programs:** 6

**Motor:** 500-3000 RPM bare motor speed

**Electrical:** 120 V, 50/60 Hz, 1.6 A

**Dimensions:** (H x W x D):  
24.0 x 10.0 x 8.3 in. / 61,0 x 25,4 x 21,0 cm

**Certifications:**

**SHIPPING:**

**Pack:** 1 per standard pack

**Carton Dimensions:** (H x W x D):  
13.0 x 11.0 x 28.0 in. / 33,0 x 27,9 x 71,1 cm

**Weight:** 25.0 lbs.

**Case Cube:** 1.9 cu. ft. / 0,05 cu. m

**WARRANTY:** The Mix'n Machine Advance is backed by a three-year warranty on motor base parts and a one-year warranty on labor. For more complete warranty terms and conditions, please call 1.800.437.4654 or visit vitamix.com.



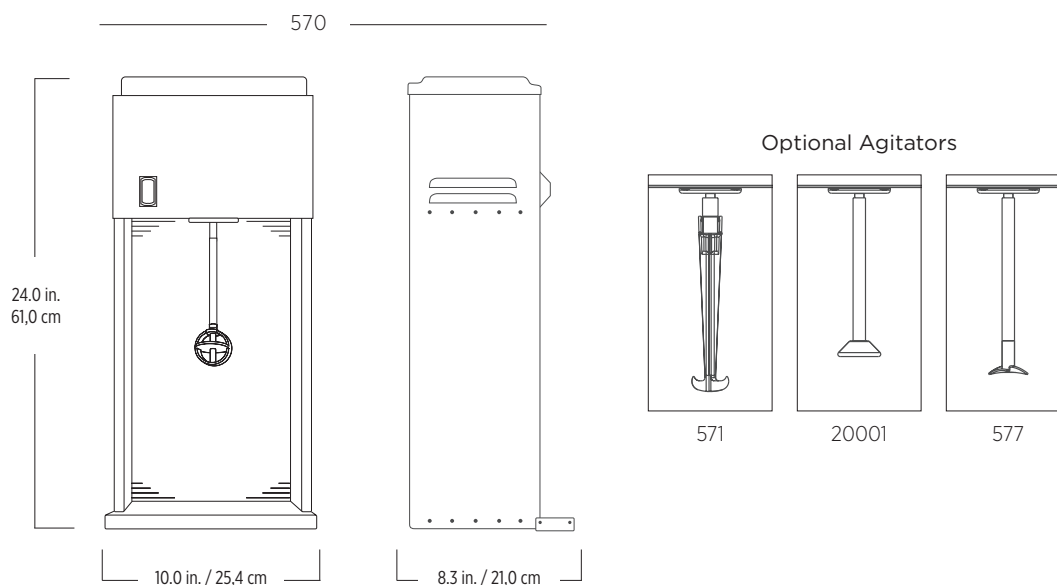

ITEM / MODEL #	DESCRIPTION	LIST PRICE
570 / VM0800	<b>Mix'n Machine On-Counter</b> with permanent soft ice cream agitator.	\$1,602.64
571 / VM0800A	<b>Mix'n Machine On-Counter</b> with removable / reusable agitator, includes 10 removable agitators.	\$1,622.97
577 / VM0800	<b>Mix'n Machine On-Counter</b> with aggressive / permanent hard ice cream agitator.	\$1,634.85
20001 / VM0800	<b>Mix'n Machine On-Counter</b> with permanent soft ice cream cone-shaped agitator.	\$1,602.64

### SPECIFICATIONS:

**Motor:** 3440 RPM bare motor speed

**Electrical:** 120 V, 50/60 Hz, 2.6 A

**Dimensions:** (H x W x D):  
24.0 x 10.0 x 8.3 in. / 61,0 x 25,4 x 21,0 cm

**Certifications:** UL us NSF

### SHIPPING:

**Pack:** 1 per standard pack

**Carton Dimensions:** (H x W x D):  
13.0 x 11.0 x 28.0 in. / 33,0 x 28,0 x 71,1 cm  
**Wall-Mount:** 14.4 x 10.0 x 18.9 in. / 36,6 x 25,4 x 48,0 cm

**Weight:** 25.0 lbs.

**Case Cube:** 1.9 cu. ft. / 0,05 cu. m

**WARRANTY:** The Mix'n Machine is backed by a three-year warranty on motor base parts and a one-year warranty on labor. For more complete warranty terms and conditions, please call 1.800.437.4654 or visit [vitamix.com](http://vitamix.com).

# EFFICIENT Blends

Each Vitamix container is designed to efficiently move ingredients toward the blades, for faster speed of service and higher quality blends. Explore our full range of containers on the following pages.



# Containers

---

- 32. Advance® Containers
- 34. Standard Containers
- 36. Specialty Containers





# Container compatibility at a glance

Find your machine in the chart below to see compatible containers.



### *The Right Equipment*

For food or beverage applications, from front-of-house to back, we've got the right machines for your business. Each Vitamix container is designed to efficiently move ingredients into the blades, for faster speed of service and higher quality blends.

COVERED BEVERAGE BLENDING			
			
		The Quiet One®	Touch & Go Advance
Advance Containers	48-ounce	✔	
	32-ounce	✔	✔
Standard Containers	64-ounce		
	48-ounce	✔	✔
	32-ounce	✔	✔
Specialty Containers	32-ounce Aerating	✔	✔
	1.5-gallon XL		
	64-ounce XL		







✔ = Container comes standard with the machine | ✔ = Container is compatible with the machine and available for purchase

- **Covered Beverage Blending** – Our quietest blenders help to provide a pleasing atmosphere for your customers.
- **Uncovered Beverage Blending** – These machines offer power and durability for the front of the house.
- **Food Preparation Blending** – Our back-of-house machines are built to perform in the toughest kitchen environments.







UNCOVERED BEVERAGE BLENDING		FOOD PREPARATION BLENDING		
				
Drink Machine™ Advance®	Drink Machine™ Two Speed	Vita-Prep® 3	Vita-Prep®	XL® Variable Speed XL® Programs
✓				
✓				
✓	✓	✓	✓	
✓	✓	✓	✓	
✓	✓	✓	✓	
		✓	✓	
				✓
				✓















48-OUNCE ADVANCE CONTAINERS

		
	<b>Complete</b>	<b>Container Only</b>
	<p>48 oz. / 1,4 L BPA-Free, Advance Container complete with Advance blade assembly and lid. NSF certified. 2.2 lbs. / 1,0 kg Dimensions (H x W x D): 8,6 x 7,1 x 8,1 in. / 21,9 x 18,0 x 20,6 cm</p> <p><b>Item / Model #:</b> 15978 / VM0143B List Price: \$228.87</p>	<p>48 oz. / 1,4 L BPA-Free, Advance Container only, no blade assembly, no lid. NSF certified. 1.0 lbs. / 0,5 kg Dimensions (H x W x D): 8,6 x 7,1 x 8,1 in. / 21,9 x 18,0 x 20,6 cm</p> <p><b>Item / Model #:</b> 16016 / VM0143B List Price: \$74.92</p>
	<b>Item / Model #:</b> 58988 / VM0143B List Price: \$228.87	<b>Item / Model #:</b> 60048 / VM0143B List Price: \$74.92
	<b>Item / Model #:</b> 58989 / VM0143B List Price: \$228.87	<b>Item / Model #:</b> 60049 / VM0143B List Price: \$74.92
	<b>Item / Model #:</b> 58990 / VM0143B List Price: \$228.87	<b>Item / Model #:</b> 60050 / VM0143B List Price: \$74.92
	<b>Item / Model #:</b> 58991 / VM0143B List Price: \$228.87	<b>Item / Model #:</b> 60051 / VM0143B List Price: \$74.92



32-OUNCE ADVANCE CONTAINERS

		
	<b>Complete</b>	<b>Container Only</b>
	<p>32 oz. / 0,9 L BPA-Free, Advance Container complete with Advance blade assembly and lid. NSF certified. 2.2 lbs. / 1,0 kg. Dimensions (H x W x D): 8,6 x 7,1 x 8,1 in. / 21,9 x 18,0 x 20,6 cm</p> <p><b>Item / Model #:</b> 15981 / VM0143C List Price: \$228.87</p>	<p>32 oz. / 0,9 L BPA-Free, Advance Container only, no blade assembly, no lid. NSF certified. 1.0 lb. / 0,5 kg. Dimensions (H x W x D): 8,6 x 7,1 x 8,1 in. / 21,9 x 18,0 x 20,6 cm</p> <p><b>Item / Model #:</b> 16019 / VM0143C List Price: \$74.92</p>
	<b>Item / Model #:</b> 58984 / VM0143C List Price: \$228.87	<b>Item / Model #:</b> 60044 / VM0143C List Price: \$74.92
	<b>Item / Model #:</b> 58985 / VM0143C List Price: \$228.87	<b>Item / Model #:</b> 60045 / VM0143C List Price: \$74.92
	<b>Item / Model #:</b> 58986 / VM0143C List Price: \$228.87	<b>Item / Model #:</b> 60046 / VM0143C List Price: \$74.92
	<b>Item / Model #:</b> 58987 / VM0143C List Price: \$228.87	<b>Item / Model #:</b> 60047 / VM0143C List Price: \$74.92

					
<b>Rubber Lid with Plug</b>	<b>One Piece Lid</b>	<b>Splash Lid Tethered Plug</b>	<b>Retainer Nut</b>	<b>Lid Plug</b>	<b>Advance Blade Assembly</b>
Rubber lid with lid plug, for Advance Container. 7.2 oz. / 0,2 kg	One piece rubber lid, for Advance Container. 7.2 oz. / 0,2 kg	Rubber splash lid with tethered lid plug, for Advance Container. 6.0 oz. / 0,2 kg	Advance retainer nut, for Advance Container. 3.6 oz. / 0,1 kg	Lid plug, for Advance Container. 0.8 oz. / 0,02 kg	Advance blade assembly, for use with Advance Container only. 8.5 oz. / 0,3 kg
<b>Item #:</b> 15985 List Price: \$51.40	<b>Item #:</b> 16090 List Price: \$51.40	<b>Item #:</b> 15092 List Price: \$39.49	<b>Item #:</b> 15585 List Price: \$41.63	<b>Item #:</b> 15987 List Price: \$16.67	<b>Item #:</b> 15990 List Price: \$133.32
N/A	<b>Item #:</b> 58992 List Price: \$51.40	<b>Item #:</b> 58996 List Price: \$39.49	N/A	N/A	<b>Item #:</b> 15990 List Price: \$133.32
N/A	<b>Item #:</b> 58993 List Price: \$51.40	<b>Item #:</b> 58997 List Price: \$39.49	N/A	N/A	<b>Item #:</b> 15990 List Price: \$133.32
N/A	<b>Item #:</b> 58994 List Price: \$51.40	<b>Item #:</b> 58998 List Price: \$39.49	N/A	N/A	<b>Item #:</b> 15990 List Price: \$133.32
N/A	<b>Item #:</b> 58995 List Price: \$51.40	<b>Item #:</b> 58999 List Price: \$39.49	N/A	N/A	<b>Item #:</b> 15990 List Price: \$133.32

					
<b>Rubber Lid with Plug</b>	<b>One Piece Lid</b>	<b>Splash Lid Tethered Plug</b>	<b>Retainer Nut</b>	<b>Lid Plug</b>	<b>Advance Blade Assembly</b>
Rubber lid with lid plug, for Advance Container. 7.2 oz. / 0,2 kg	One piece rubber lid, for Advance Container. 7.2 oz. / 0,2 kg	Rubber splash lid with tethered lid plug, for Advance Container. 6.0 oz. / 0,2 kg	Advance retainer nut, for Advance Container. 3.6 oz. / 0,1 kg	Lid plug, for Advance Container. 0.8 oz. / 0,02 kg	Advance blade assembly, for use with Advance Container only. 8.5 oz. / 0,3 kg
<b>Item #:</b> 15985 List Price: \$51.40	<b>Item #:</b> 16090 List Price: \$51.40	<b>Item #:</b> 15092 List Price: \$39.49	<b>Item #:</b> 15585 List Price: \$41.63	<b>Item #:</b> 15987 List Price: \$16.67	<b>Item #:</b> 15990 List Price: \$133.32
N/A	<b>Item #:</b> 58992 List Price: \$51.40	<b>Item #:</b> 58996 List Price: \$39.49	N/A	N/A	<b>Item #:</b> 15990 List Price: \$133.32
N/A	<b>Item #:</b> 58993 List Price: \$51.40	<b>Item #:</b> 58997 List Price: \$39.49	N/A	N/A	<b>Item #:</b> 15990 List Price: \$133.32
N/A	<b>Item #:</b> 58994 List Price: \$51.40	<b>Item #:</b> 58998 List Price: \$39.49	N/A	N/A	<b>Item #:</b> 15990 List Price: \$133.32
N/A	<b>Item #:</b> 58995 List Price: \$51.40	<b>Item #:</b> 58999 List Price: \$39.49	N/A	N/A	<b>Item #:</b> 15990 List Price: \$133.32

64-OUNCE STANDARD CONTAINERS





		
	<b>Complete</b>	<b>Container Only</b>
	64 oz. / 2,0 L BPA-Free, clear container with wet blade assembly and lid. NSF certified. 3.2 lbs. / 1,5 kg. Dimensions (H x W x D): 13,4 x 7,6 x 9,1 in. / 34,0 x 19,3 x 23,1 cm	64 oz. / 2,0 L BPA-Free, clear container only, no blade assembly, no lid. NSF certified. 2.4 lbs. / 1,1 kg. Dimensions (H x W x D): 13,4 x 7,6 x 9,1 in. / 34,0 x 19,3 x 23,1 cm
	<b>Item / Model #:</b> 1195 / VM0135 List Price: \$201.60	<b>Item / Model #:</b> 58625 / VM0135 List Price: \$61.30
<b>Yellow Allergen Container</b>	<b>Item / Model #:</b> 67403 / VM0135 List Price: \$201.60	<b>Item / Model #:</b> 67404 / VM0135 List Price: \$61.30



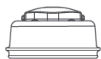

48-OUNCE STANDARD CONTAINERS





		
	<b>Complete</b>	<b>Container Only</b>
	48 oz. / 1,4 L BPA-Free, clear / stackable container with wet blade assembly and lid. NSF certified. 2.0 lbs. / 0,9 kg. Dimensions (H x W x D): 13,4 x 7,6 x 9,1 in. / 34,0 x 19,3 x 23,1 cm	48 oz. / 1,4 L BPA-Free, clear / stackable container only, no blade assembly, no lid. NSF certified. 1.3 lbs. / 0,6 kg. Dimensions (H x W x D): 13,4 x 7,6 x 9,1 in. / 34,0 x 19,3 x 23,1 cm
	<b>Item / Model #:</b> 15504 / VM0136 List Price: \$201.60	<b>Item / Model #:</b> 58805 / VM0136 List Price: \$61.30

32-OUNCE STANDARD CONTAINERS

		
	<b>Complete</b>	<b>Container Only</b>
	32 oz. / 0,9 L compact BPA-Free, clear / stackable container with wet blade assembly and lid. NSF certified. 2.6 lbs. / 1,2 kg. Dimensions (H x W x D): 13,4 x 7,6 x 9,1 in. / 34,0 x 19,3 x 23,1 cm	32 oz. / 0,9 L compact BPA-Free, clear / stackable container only, no blade assembly, no lid. NSF certified. 1.8 lbs. / 0,8 kg. Dimensions (H x W x D): 13,4 x 7,6 x 9,1 in. / 34,0 x 19,3 x 23,1 cm
	<b>Item / Model #:</b> 15652 / VM0137 List Price: \$201.60	<b>Item / Model #:</b> 15643 / VM0137 List Price: \$61.30

				
<b>Two Piece Lid</b>	<b>Retainer Nut</b>	<b>Lid Plug</b>	<b>Wet Blade</b>	<b>Tamper</b>
Two-piece thermoplastic rubber lid with lid plug, for 64 oz. / 2.0 L container. 7.2 oz. / 0.2 kg	Retainer nut, for standard containers (32 oz./0.9 L – 48 oz./1.4 L – 64 oz./2.0 L). 1.0 lb. / 0.5 kg	Lid plug, for 64 oz. / 2.0 L high-impact, clear container. 1.6 oz. / 0.05 kg	Wet blade assembly. 6.4 oz. / 0.2 kg	Tamper. 3.2 oz. / 0.1 kg
<b>Item #:</b> 1191 List Price: \$51.40	<b>Item #:</b> 836 List Price: \$41.63	<b>Item #:</b> 62984 List Price: \$20.82	<b>Item #:</b> 1152 List Price: \$119.46	<b>Item #:</b> 760 List Price: \$16.67
<b>Item #:</b> 067405 List Price: \$49.42	N/A	N/A	N/A	N/A



				
<b>Two Piece Lid</b>	<b>Retainer Nut</b>	<b>Lid Plug</b>	<b>Wet Blade</b>	<b>Tamper</b>
Two-piece thermoplastic rubber lid with plug, for 48 oz. / 1.4 L polycarbonate container. 4.8 oz. / 0.1 kg	Retainer nut, for standard containers (32 oz./0.9 L – 48 oz./1.4 L – 64 oz./2.0 L). 1.0 lb. / 0.5 kg	Lid plug for 48 oz. / 1.4 L high-impact, clear / stackable container. 0.8 oz. / 0.02 kg	Wet blade assembly. 6.4 oz. / 0.2 kg	Tamper. 3.2 oz. / 0.1 kg
<b>Item #:</b> 15507 List Price: \$51.40	<b>Item #:</b> 836 List Price: \$41.63	<b>Item #:</b> 15987 List Price: \$16.67	<b>Item #:</b> 1152 List Price: \$119.46	<b>Item #:</b> 760 List Price: \$16.67

				
<b>Two Piece Lid</b>	<b>Retainer Nut</b>	<b>Lid Plug</b>	<b>Wet Blade</b>	<b>Tamper</b>
Two-piece thermoplastic rubber lid with plug, for 32 oz. / 0.9 L compact high-impact, clear / stackable container. 5.7 oz. / 0.2 kg	Retainer nut, for standard containers (32 oz./0.9 L – 48 oz./1.4 L – 64 oz./2.0 L). 1.0 lb. / 0.5 kg	Lid plug for 32 oz. / 0.9 L compact container lid only. 1.7 oz. / 0.05 kg	Wet blade assembly. 6.4 oz. / 0.2 kg	Tamper. 3.2 oz. / 0.1 kg
<b>Item #:</b> 15647 List Price: \$51.40	<b>Item #:</b> 836 List Price: \$41.63	<b>Item #:</b> 15851 List Price: \$20.82	<b>Item #:</b> 1152 List Price: \$119.46	<b>Item #:</b> 760 List Price: \$16.67



# Smart Product Design

- 1.5-gallon XL container allows you to blend up to 24 servings in a single blend, minimizing prep time and improving speed of service.
- With shatter-proof polycarbonate and a hardened stainless-steel blade, XL containers are built to last.
- The vented lid plug releases steam, allowing you to blend hot mixtures and add ingredients while processing.

## 1.5-GALLON FOR XL





		
	<b>Complete</b>	<b>Container Only</b>
	1.5 gal. / 5,6 L container complete with XL blade assembly, lid and lid plug. For use with Vitamix XL only. NSF certified. Dimensions (H x W x D): 13,5 x 12,1 x 12,1 in. / 34,3 x 30,7 x 30,7 cm	1.5 gal. / 5,6 L container only, no blade assembly, no lid, no lid plug. For use with Vitamix XL only. NSF certified. Dimensions (H x W x D): 12,1 x 8,8 x 12,1 in. / 30,7 x 22,4 x 30,7 cm
	<b>Item / Model #:</b> 15899 / VM0142 List Price: \$535.13	<b>Item / Model #:</b> 15896 / VM0142 List Price: \$125.78





## 64-OUNCE FOR XL

		
	<b>Complete</b>	<b>Container Only</b>
	64 oz. / 2,0 L container complete with XL blade assembly, lid and lid plug. For use with Vitamix XL only. NSF certified. Dimensions (H x W x D): 13,1 x 7,1 x 8,2 in. / 33,3 x 18,0 x 20,8 cm	64 oz. / 2,0 L container only, no blade assembly, no lid, no lid plug. For use with Vitamix XL only. NSF certified. Dimensions (H x W x D): 8,6 x 7,1 x 8,2 in. / 21,8 x 18,0 x 20,8 cm
	<b>Item / Model #:</b> 15894 / VM0143 List Price: \$253.79	<b>Item / Model #:</b> 15893 / VM0143 List Price: \$79.44





				
<b>Two Piece Lid</b>	<b>Retainer Nut</b>	<b>Lid Plug</b>	<b>XL Blade for use with 1.5-gallon container</b>	<b>Tamper</b>
Lid and lid plug, for use with Vitamix XL 1.5 gal. / 5,6 L container only. Dimensions (H x W x D): 3.9 x 12.1 x 8.5 in. / 9.9 x 30.7 x 21.6 cm	1.5 gal. / 5,6 L retainer nut. For use with Vitamix XL only.	Lid plug for use with Vitamix XL 1.5 gal. / 5,6 L container only. 1.6 oz. / 0,1 kg	Blade assembly, for use with Vitamix XL 1.5 gal. / 5,6 L container only.	Tamper. 3.2 oz. / 0,1 kg
<b>Item #:</b> 15900 <b>List Price:</b> \$71.73	<b>Item #:</b> 15901 <b>List Price:</b> \$49.66	<b>Item #:</b> 62984 <b>List Price:</b> \$20.82	<b>Item #:</b> 15897 <b>List Price:</b> \$375.14	<b>Item #:</b> 760 <b>List Price:</b> \$16.67

				
<b>Two Piece Lid</b>	<b>Retainer Nut</b>	<b>Lid Plug</b>	<b>XL Blade for use with 64-ounce container</b>	<b>Tamper</b>
Lid and lid plug, for use with Vitamix XL 64 oz. / 2,0 L container only. Dimensions (H x W x D): 6.4 x 7.0 x 5.9 in. / 16.3 x 17.8 x 15,0 cm	Retainer nut, for use with Vitamix XL 64 oz. / 2,0 L container only.	Lid plug for use with Vitamix XL 64 oz. / 2,0 L container only. 1.6 oz. / 0,1 kg	Blade assembly, for use with Vitamix XL 64 oz. / 2,0 L container only	Tamper. 3.2 oz. / 0,1 kg
<b>Item #:</b> 15892 <b>List Price:</b> \$58.49	<b>Item #:</b> 15942 <b>List Price:</b> \$49.66	<b>Item #:</b> 62984 <b>List Price:</b> \$20.82	<b>Item #:</b> 15941 <b>List Price:</b> \$176.53	<b>Item #:</b> 760 <b>List Price:</b> \$16.67



FINESSE DELICATE

# Blends

---

Sometimes, the most powerful thing you can be is gentle.





Our Aerating Container is ideal for fine-tuning delicate blends like emulsions, culinary foams, whipped cream, and more. From oxidizing citrus juice to making large batches of foam, the disc blade delivers an easy way to create new textures in the kitchen.

# Smart Product Design

- Disc blade design creates dense and pourable culinary foam, flavored whipped cream, mousse, infusions, and emulsions with minimal splashing.
- BPA-Free Eastman Tritan™ copolyester and double-sealed bearings provide strength and durability.
- Provides the flexibility to blend at a variety of speed settings.
- Compatible with The Quiet One®, Blending Station® Advance®, Vita-Prep®, and Vita-Prep® 3.



## 32-OUNCE AERATING CONTAINER

<b>Complete</b>	<b>Item #:</b> 62947 List Price: \$223.86		32 oz. / 0,9 L compact BPA-Free, clear / stackable container with aerating blade assembly, lid and mini tamper. NSF certified. 2.6 lbs. / 1,2 kg. Dimensions (H x W x D): 13,4 x 7,6 x 9,1 in. / 34,0 x 19,3 x 23,1 cm
<b>Retainer Nut</b>	<b>Item #:</b> 836 List Price: \$41.63		Retainer nut, for standard containers (32 oz. / 0,9 L - 48 oz. / 1,4 L - 64 oz. / 2,0 L). 1.0 lb. / 0,5 kg
<b>Two Piece Lid</b>	<b>Item #:</b> 15647 List Price: \$51.40		Two-piece thermoplastic rubber lid with plug, for 32 oz. / 0,9 L compact high-impact, clear / stackable container. 5.7 oz. / 0,2 kg
<b>Lid Plug</b>	<b>Item #:</b> 15851 List Price: \$20.82		Lid plug for 32 oz. / 0,9 L compact container lid only. 1.7 oz. / 0,05 kg
<b>Mini Tamper</b>	<b>Item #:</b> 15033 List Price: \$16.67		Mini Tamper. 3.2 oz. / 0,1 kg

FIND YOUR  
**Accessories**

From accessories to replacement parts, we offer everything you need to keep your machine performing at its highest level, day after day, for years to come.

---





## Accessories & Parts

---

- 44. Rinsers
- 45. Sound Enclosures
- 45. Programming
- 45. Centering Pads
- 46. Drive Sockets, Repair Kits
- 47. Mix'n Machine®





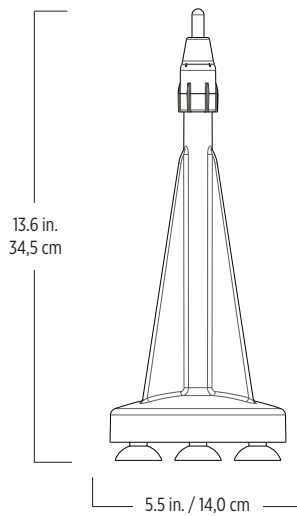

ITEM / MODEL #	DESCRIPTION	LIST PRICE
1442 / VM0134	<b>Rinse-O-Matic</b> blender container rinser, includes base, 2.5 ft. / 76,2 cm hose assembly, Y connector, faucet adapters and instructions.	\$379.40
1445 / VM0134	Carton of 12 <b>Rinse-O-Matic</b> blender container rinsers.	\$3,765.53

**SPECIFICATIONS:**

**PSI:** Cold water from a faucet with a minimum 25 psi / maximum 80 psi of pressure

**Dimensions:** (H x W x D):  
13.6 x 5.5 in. / 34,5 x 14,0 cm

**Certifications:** NSF

**SHIPPING:**

**Pack:** 1442: 1 per standard pack  
1445: 12 per standard pack

**Carton Dimensions:** (H x W x D):  
1442: 14.0 x 6.8 x 6.8 in. / 35,6 x 17,3 x 17,3 cm  
1445: 14.5 x 20.5 x 27.5 in. / 36,8 x 52,1 x 69,9 cm

**Weight:** 1442: 2.2 lbs.  
1445: 31.0 lbs

**Case Cube:** 1442: 0.4 cu. ft. / 0,01 cu. m  
1445: 4.7 cu. ft. / 0,1 cu. m

**WARRANTY:** The Rinse-O-Matic is backed by a one-year warranty on parts. For more complete warranty terms and conditions, please call 1.800.437.4654 or visit vitamix.com.

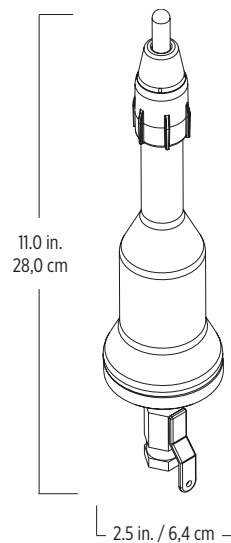

ITEM #	DESCRIPTION	LIST PRICE
1462	<b>Sink Mount Rinse-o-matic</b> - includes Rinse-o-matic blender container rinser base, valve, and instructions.	\$313.22

**SPECIFICATIONS:**

**PSI:** Cold water from a faucet with a minimum 25 psi / maximum 80 psi of pressure

**Dimensions:** (H x W x D):  
11.0 x 2.5 x 2.5 in / 28,0 x 6,4 x 6,4 cm

**SHIPPING:**

**Pack:** 1 per standard pack

**Carton Dimensions:** (H x W x D):  
14.0 x 6.8 x 6.8 in. / 35,6 x 17,3 x 17,3 cm

**Weight:** 0.91 lbs.

**Case Cube:** 0.4 cu. ft. / 0,01 cu. m





**WARRANTY:** The Sink Mount Rinse-o-matic is backed by a one-year warranty on parts. For more complete warranty terms and conditions, please call 1.800.437.4654 or visit vitamix.com.

**NOTE:** A 1 3/4" diameter hole must be drilled in sink to allow for installation.



# Find Your Accessories

Locate your machine in the following charts to find replacement parts and compatible accessories.

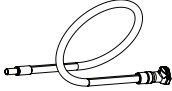

## RINSERS — REPLACEMENT PARTS

Rinse-O-Matic®	<b>Item #:</b> 1415 List Price: \$34.08		Faucet adapter kit, includes various adapters – 5 per standard pack. 2.3 oz. / 0,1 kg
Rinse-O-Matic®	<b>Item #:</b> 1419 List Price: \$21.00		Y faucet connector. 4.9 oz. / 0,1 kg
Rinse-O-Matic®	<b>Item #:</b> 1437 List Price: \$48.71		Quick disconnect insert (male). 0.5 oz. / 0,01 kg
Rinse-O-Matic® In Sink Rinse-O-Matic®	<b>Item #:</b> 1443 List Price: \$45.80		Rinse-O-Matic sprayhead / activator replacement kit, includes sprayhead and valve assembly. 0.64 oz. / 0,02 kg
Rinse-O-Matic®	<b>Item #:</b> 1444 List Price: \$46.21		Feet replacement kit, includes rubber suction cup feet – 3 per standard pack. 0.4 oz. / 0,01 kg
Rinse-O-Matic®	<b>Item #:</b> 1448 List Price: \$189.05		Rinse-O-Matic hose assembly replacement kit, includes 2.5 ft. / 76,2 cm clear PVC hose, and 2 connectors. 5.4 oz. / 0,2 kg

## SOUND ENCLOSURES — REPLACEMENT PARTS

The Quiet One® (Twist Lock) Touch & Go Advance	<b>Item #:</b> 67879 List Price: \$510.84		Complete two-piece Twist Lock copolyester plastic compact cover with removable cover hinge. For The Quiet One, The Quiet One Twist Lock and Touch & Go Advance only.
	<b>Item #:</b> 067877 List Price: \$326.33		Twist Lock copolyester plastic compact cover back only. For The Quiet One, The Quiet One Twist Lock and Touch & Go Advance only.
	<b>Item #:</b> 15081 List Price: \$227.50		Copolyester plastic compact cover door only. For The Quiet One only. 2.4 lbs. / 1,1 kg.

## PROGRAMMING — REPLACEMENT PARTS









The Quiet One® Drink Machine™ Advance® XL® Programs	<b>Item #:</b> 15606 List Price: \$308.53		Programmer software kit for the TQO, DMA, and XL Programs. Includes USB cable with programming module, instruction manual and CD. (Not compatible with Apple/Mac)
	<b>Item #:</b> 15644 List Price: \$58.23		Extra program chip for programmer software kit. <b>Note:</b> Specify custom program needed if necessary.
	<b>Item #:</b> 15645 List Price: \$355.06		Extra program chips for programmer software kit – 10 per standard package. <b>Note:</b> Specify custom program needed if necessary.

## CENTERING PADS — REPLACEMENT PARTS





The Quiet One® (Twist Lock) Touch & Go Advance	<b>Item #:</b> 067876 List Price: \$61.24		Sound-reducing centering pad, for TQO (Twist Lock) and Touch & Go Advance. 0,1 kg
Drink Machine™ Advance®	<b>Item #:</b> 15578 List Price: \$20.82		Sound-reducing centering pad, for Drink Machine Advance. 3.5 oz. / 0,1 kg
Drink Machine™ Two-Speed Vita-Prep® 3 Vita-Prep®	<b>Item #:</b> 791 List Price: \$20.82		Sound-reducing centering pad. 4.0 oz. / 0,11 kg
XL® Variable Speed XL® Programs	<b>Item #:</b> 15895 List Price: \$20.82		Sound-reducing centering pad, for Vitamix XL, 1 per standard pack. 3.5 oz. /,1kg





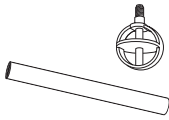
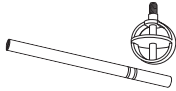
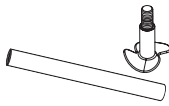

**DRIVE SOCKET, REPAIR KITS — REPLACEMENT PARTS**

<p>The Quiet One®                  Touch and Go Advance                  Drink Machine™ Advance®                  Drink Machine™ Two-Speed                  Vita-Prep® 3                  Vita-Prep®</p>	<p><b>Item #:</b> 15519                  List Price: \$156.52</p>		<p>Repair kit with tool box, includes 5 drive sockets, retainer nut wrench, silicone sealant tube, Allen wrench, and maintenance manual. 3.0 lbs. / 1,4 kg</p>
<p>The Quiet One®                  Touch and Go Advance                  Drink Machine™ Advance®                  Drink Machine™ Two-Speed                  Vita-Prep® 3                  Vita-Prep®</p>	<p><b>Item #:</b> 891                  List Price: \$17.28</p>		<p>Drive socket kit with 1 drive socket, includes Allen wrench and instructions. 1.6 oz. / 0,05 kg</p>
	<p><b>Item #:</b> 15546                  List Price: \$34.62</p>		<p>Drive socket kit with 2 drive sockets, includes Allen wrench and instructions. 2.0 oz. / 0,06 kg</p>
	<p><b>Item #:</b> 15547                  List Price: \$83.62</p>		<p>Drive socket kit with 5 drive sockets, includes Allen wrench and instructions. 4.0 oz. / 0,1 kg</p>
<p>XL® Variable Speed                  XL® Programs</p>	<p><b>Item #:</b> 15902                  List Price: \$20.96</p>		<p>Drive socket kit with 1 drive socket, includes Allen wrench and instructions. For use with Vitamix XL only. 1.6 oz. / 0,05 kg</p>
	<p><b>Item #:</b> 15903                  List Price: \$41.94</p>		<p>Drive socket kit with 2 drive sockets, includes Allen wrench and instructions. For use with Vitamix XL only. 2.0 oz. / 0,06 kg</p>
	<p><b>Item #:</b> 15904                  List Price: \$99.32</p>		<p>Drive socket kit with 5 drive sockets, includes Allen wrench and instructions. For use with Vitamix XL only. 4.0 oz. / 0,11 kg</p>
<p>The Quiet One®                  Touch and Go Advance                  Drink Machine™ Advance®                  Drink Machine™ Two-Speed                  Vita-Prep® 3                  Vita-Prep®                  XL® Variable Speed                  XL® Programs</p>	<p><b>Item #:</b> 15596                  List Price: \$20.82</p>		<p>Retainer nut wrench, plastic. 3.2 oz. / 0,1 kg</p>

## MIX'N MACHINE | MIX'N MACHINE ADVANCE — REPLACEMENT PARTS

Mix'n Machine® Mix'n Machine® Advance®	<b>Item #:</b> 30019 List Price: \$7.42		Permanent soft ice cream agitator. 0.8 oz. / 0,02 kg
Mix'n Machine® Mix'n Machine® Advance®	<b>Item #:</b> 30060 List Price: \$7.72		Permanent soft ice cream cone-shaped agitator. 0.8 oz. / 0,02 kg
Mix'n Machine® Mix'n Machine® Advance®	<b>Item #:</b> 30003 List Price: \$56.92		Removable agitators – 10 per standard pack. 0.4 oz. / 0,01 kg <b>Note:</b> Must be used with removable agitator shaft.
Mix'n Machine® Mix'n Machine® Advance®	<b>Item #:</b> 30018 List Price: \$66.29		Aggressive / permanent hard ice cream agitator. 0.8 oz. / 0,02 kg
Mix'n Machine® Mix'n Machine® Advance®	<b>Item #:</b> 80 List Price: \$27.19		Conversion kit: permanent soft / hard ice cream agitator to removable / reusable agitator. Contains 1 removable agitator shaft. 2.5 oz. / 0,07 kg
Mix'n Machine® Mix'n Machine® Advance®	<b>Item #:</b> 81 List Price: \$60.11		Conversion kit for on-counter models: removable / reusable agitator to permanent soft ice cream agitator. Contains 1 permanent soft ice cream agitator (#30019), and 1 countertop agitator shaft (#30023). 2.5 oz. / 0,1 kg
Mix'n Machine®	<b>Item #:</b> 30004 List Price: \$62.47		Conversion kit for wall-mount models: removable / reusable agitator to permanent soft ice cream agitator. Contains 1 permanent soft ice cream agitator (#30019), and 1 wall-mount agitator shaft (#30034). 3.0 oz. / 0,1 kg
Mix'n Machine® Mix'n Machine® Advance®	<b>Item #:</b> 30006 List Price: \$125.91		Conversion kit: removable / reusable agitator to aggressive / permanent hard ice cream agitator. Contains 1 permanent hard ice cream agitator (#30018), and 1 countertop agitator shaft (#30023). 3.4 oz. / 0,1 kg

MIX'N MACHINE | MIX'N MACHINE ADVANCE – REPLACEMENT PARTS

Mix'n Machine®	<b>Item #:</b> 30000 List Price: \$124.64		Guarded air-activated foot control for 120 V models only. 2.2 lbs. / 0,1 kg
Mix'n Machine® Mix'n Machine® Advance®	<b>Item #:</b> 30015 List Price: \$30.68		Splash guard for on-counter models. 9.5 oz. / 0,3 kg
Mix'n Machine®	<b>Item #:</b> 30029 List Price: \$31.57		Moving splash guard for wall-mount models. 9.5 oz. / 0,3 kg
Mix'n Machine® Mix'n Machine® Advance®	<b>Item #:</b> 30023 List Price: \$63.44		Agitator shaft for standard on-counter models.
Mix'n Machine® Mix'n Machine® Advance®	<b>Item #:</b> 15668 List Price: \$71.30		Wall mounting (bracket) kit. 2.0 lbs / 0,9 kg

**TO PLACE AN ORDER:***(Choose one of the following methods)***By Email:****commercial@vitamix.com****By Fax:****+1 440.235.9670****REQUIRED INFORMATION ON ORDERS:**

Vitamix requires that all purchase orders accurately identify the following minimum information:

- Vitamix account number
- P.O. number
- Payment terms
- Bill to address: business name, street address, city, state, zip code, phone number, fax number or email address, and primary contact person
- Ship to address: business name, street address, city, state, zip code, phone number, fax number or email address, and a contact person (**Note: orders can not be shipped to a P.O. Box**)
- Requested delivery date
- Preferred shipping method
- Vitamix item number
- Item number description
- Quantity per item number being ordered
- Item price

**TERMS:**

- This catalog contains U.S. 120V Vitamix products that are only applicable for sale in the U.S.
- The exporting of U.S. Vitamix products is strictly prohibited and voids all warranty.
- All prices are in U.S. dollars and are subject to change without notice.
- All orders are subject to acceptance by Vitamix.
- A minimum order of \$50.00 is required.
- Any single order in excess of \$6000 Net (\$7500 Net when ordering an XL) shipping to the same destination within the contiguous United States of America will receive free ground shipping via the carrier chosen by Vitamix.
- All orders that do not include specific shipping instructions will be shipped via ground freight by the carrier chosen by Vitamix.
- Shipping and handling charges will be applied to each order based on the standard rates charged by the selected carrier.
- A drop ship fee of \$15.00 per order applies when shipping machines to a different destination than the billing address.
- Vitamix is not liable for any type of theft or fraud related to drop ship orders. Signature required is recommended on all drop ship orders. Additional fee applies.

## TO PLACE AN ORDER:

*(Continued)*

- All air shipment charges are the responsibility of the requester and will be included in the shipping and handling fees.
- EXW Cleveland, Ohio U.S.A. Net 30 days from date of invoice with approved credit. Allow 10 business days for credit application to process.
- 1.5% monthly (18% annually) service charge added on all accounts past due.
- \$20.00 fee charged for all returned checks.

## DAMAGES AND SHORTAGES / RETURNS FREIGHT:

- Inspect your shipment immediately. The transportation company is responsible for the merchandise while it is in transit to you.
- If there is a shortage or damage to your shipment, action must be taken by you to notify the carrier upon arrival of shipment to ensure approval of claim. It is the duty and responsibility of the delivering carrier to give you a written report of such shortage or damage following notification.
- Concealed damage: If the damage is concealed, notify the carrier within 48 hours, by phone and in writing, asking them to send their agent to complete an inspection report. Retain all cartons and merchandise for their inspection report and claim approval. It is critical that you file a written claim with the carrier within 48 hours of receipt of shipment for any shortage or concealed damage. Enclose with your claim: Carrier's Inspection Report, paid freight bill and original or certified copy of invoice.

## RETURNS:

- Before returning any product, please contact our customer service department at 1.800.4DRINK4. Vitamix is not responsible for items returned without authorization.
- Goods may not be returned without a return authorization (RA) number from Vitamix.
- All cartons returned must be marked with the return authorization number. In order for merchandise to be returned, it should be in the original carton and unopened.
- Absolutely no returns will be accepted after 120 days of ship date.
- Special merchandise built to a buyer's specification may not be returned.
- Returned goods must be shipped to Vitamix prepaid and will be credited at invoice less 20% restocking charge.
- The restocking charge will be reduced to 10% if a replacement unit is ordered at time of return.

## CONTACT:

### U.S.A.

Phone: 800.437.4654  
 Fax: +1 440.235.9670  
 Email: commercial@vitamix.com

### Outside U.S.A.

Phone: +1 440.782.2450  
 Fax: +1 440.782.2220  
 Email: international@vitamix.com

For more information on international products, please contact Vitamix.

Warranties listed in this price book are applicable to the United States only. Please see the owner's manual for complete warranty details. For equipment and warranties outside of the United States, contact a Vitamix authorized international distributor or contact Vitamix for a distributor near you.

Any other use or distribution of this price list, direct or indirect, or the information herein without the written permission of Vita-Mix Corporation is forbidden.





WE'RE HERE TO HELP

---

*Sales Support*

Our passion for world-class customer service runs deep within our roots as a company. Our dedicated sales representatives are here to answer all of your product questions, please email [international@vitamix.com](mailto:international@vitamix.com).

*Technical Support*

Please reach out to our Commercial Customer Service team in Cleveland, Ohio at [commercialts@vitamix.com](mailto:commercialts@vitamix.com)

